

High-Voltage Types Outline Drawings and Specifications

Type 271

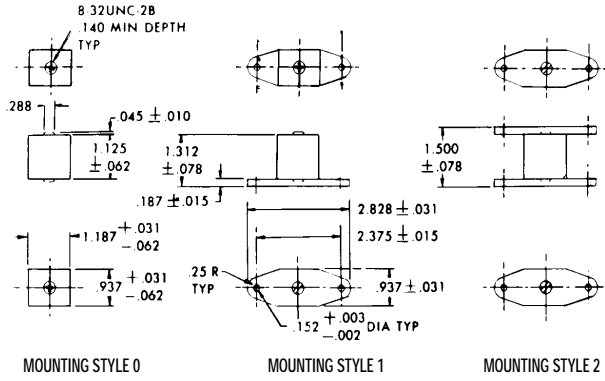

Type 273

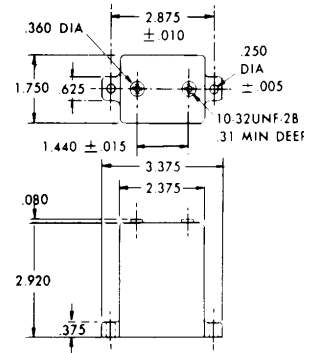

TOLERANCES UNLESS
OTHERWISE SPECIFIED: ±031

Type 272

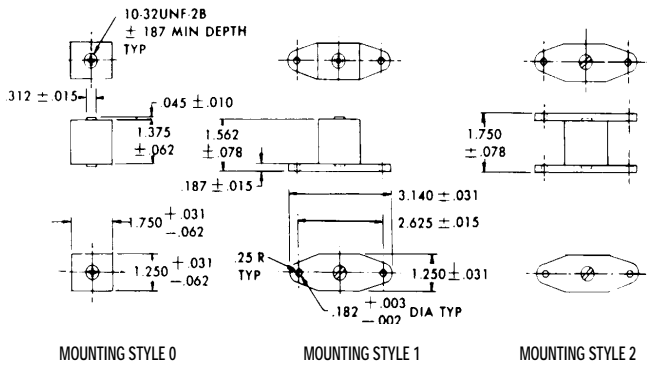

Cast-Case Styles

Type 291

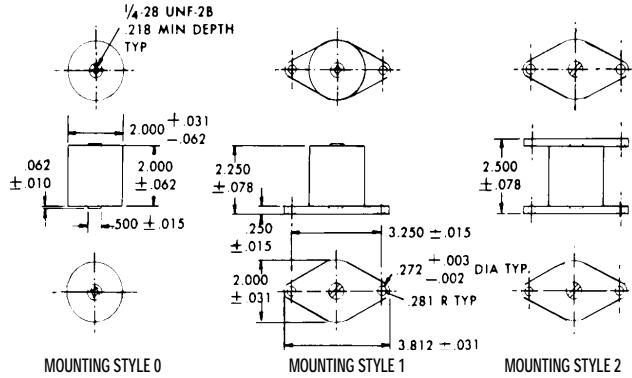

Type 292

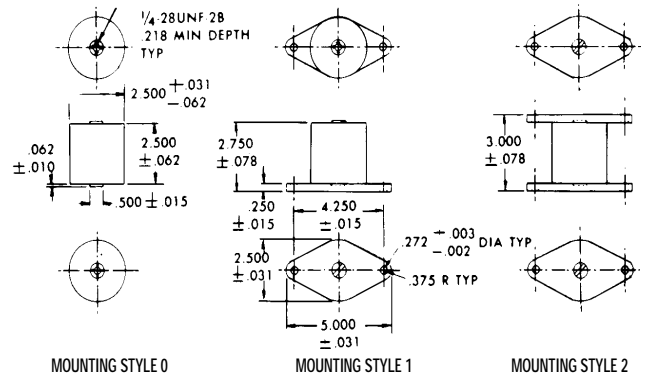

Type 293

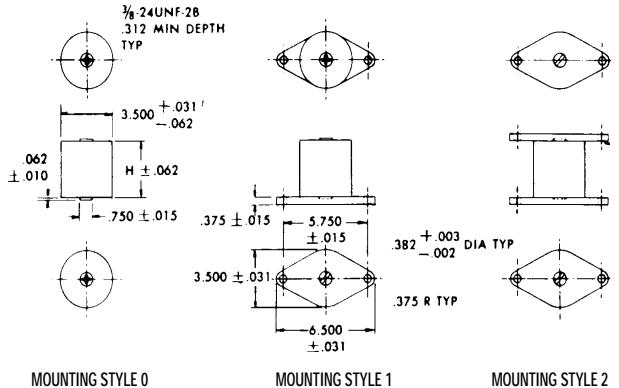

Type 294

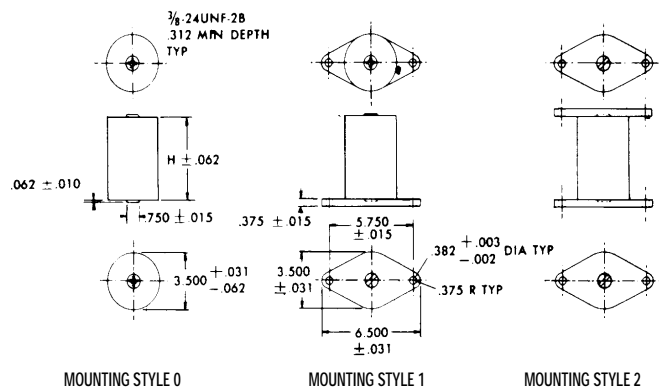

High-Voltage Types Outline Drawings and Specifications

Type 271 (CM 66)
Rated Current Versus Frequency

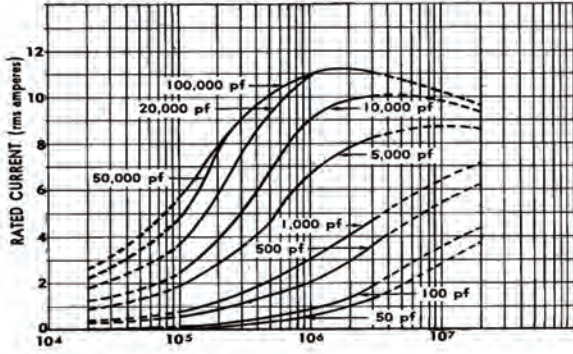

Type 272 (CM 71)
Rated Current Versus Frequency

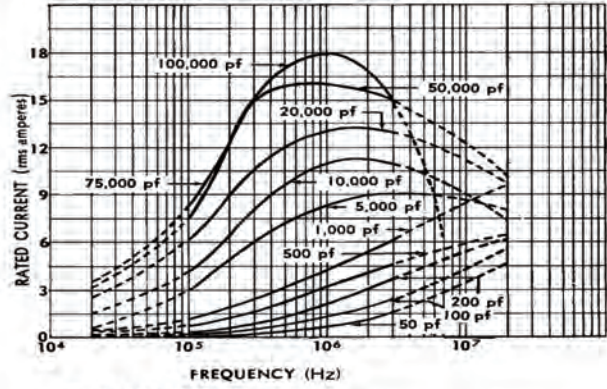

Type 273
Rated Current Versus Frequency

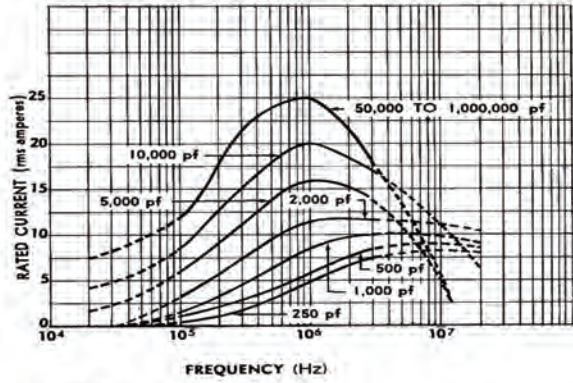

Type 291 (CM 76)
Rated Current Versus Frequency

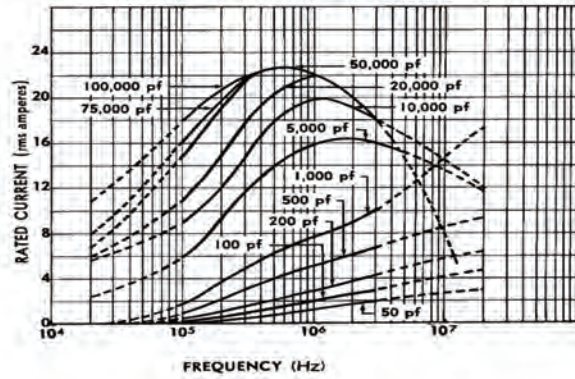

Type 292 (CM 81)
Rated Current Versus Frequency

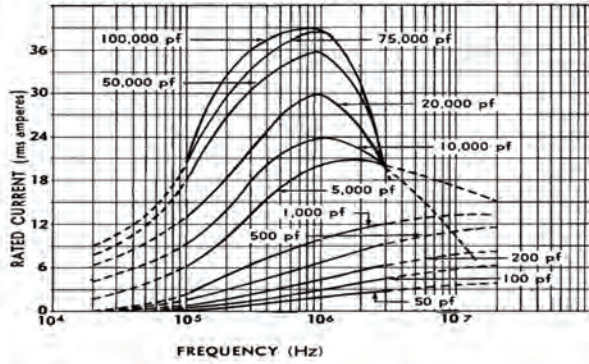

Type 293 (CM 86)
Rated Current Versus Frequency

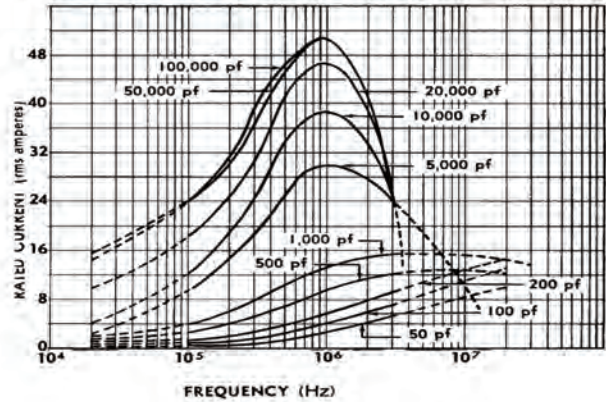

Type 294 (CM 91)
Rated Current Versus Frequency

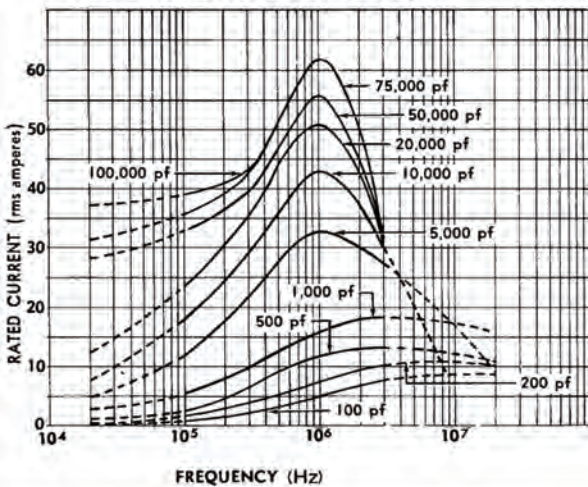

Type G5 (CM 95)
Rated Current Versus Frequency

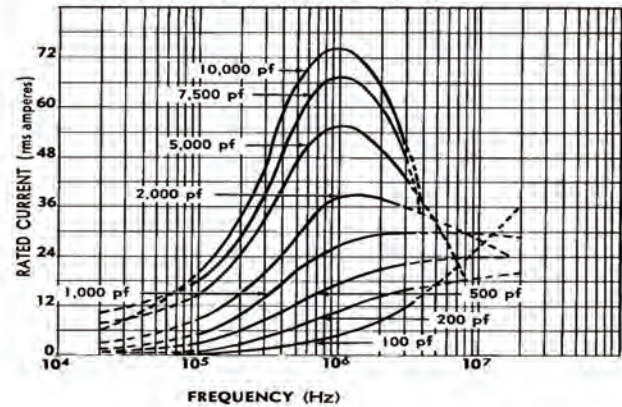

High-Voltage Types Outline Drawings and Specifications

Specifications

Capacitance is within tolerance when measured at these frequencies:

1–1000 pF @ 1 MHz

> 1000 pF @ 1 kHz

Dissipation Factor is typically less than 0.05% when measured as above. Dissipation factor (DF) equals $2\pi fRC$, where f is the test frequency, R is the equivalent series resistance (Ω), and C is nominal capacitance (F). Q is the reciprocal of the dissipation factor.

Operating Temperature Range is -55°C to $+125^\circ\text{C}$. Insulation Resistance is no less than 7500 M Ω when measured at 100 Vdc.

Temperature Coefficient and Capacitance Drift: Measure the capacitors' capacitance at 25°C , 55°C , 25°C , 125°C , and at 25°C after stabilizing at each temperature. The capacitance will meet the limits of the Characteristic table shown in Ordering Information.

Rated Peak Voltage is not to be exceeded in actual use. Voltage ratings are in the listings and apply under the following conditions:

Temperature: Within the specified operating temperature range.

Altitude: Up to 50,000 feet or 3.4 inches of mercury.

Relative Humidity: Up to 80%.

Frequency: As specified.

Where pulse conditions are encountered, contact us.

Withstanding Voltage: Capacitors will withstand application of an ac potential between terminals having an rms value equal to the rated peak voltage at a frequency of 100 Hz or less without damage, arcing or breakdown. Apply the potential by raising the voltage from zero to the specified value. Apply the full potential for a minimum of 5 seconds.

Case Insulation: Capacitor cases will withstand, without damage, arcing or breakdown, a 60-Hz peak ac potential equal to twice the rated peak voltage applied between the terminals connected together and a metal electrode touching the case. Apply this potential for 1 to 5 seconds.

Current Ratings at various frequencies are in the listings and apply under the following conditions:

Temperature: 65°C maximum

Derating Factor: None

Vibration: Capacitors will withstand vibrational forces occurring at rates of from 10 to 55 Hz for $4\frac{1}{2}$ hours. The total excursion during vibration is 0.06 inches. At the end of this period, make the following inspections and tests:

Visual and Mechanical Inspection: No perceptible deterioration. Withstanding Voltage: As specified under Withstanding Voltage.

Insulation Resistance: No less than 7500 M Ω .

Capacitance Change: Not to exceed 3% of the nominal value or one picofarad, whichever is greater.

Temperature and Immersion Cycling: Capacitors will withstand the temperature and immersion cycles indicated in the tables below. Follow three temperature cycles by two immersion cycles. Make the measurements listed below no more than 30 minutes following the final immersion cycle:

Withstanding Voltage: As specified under Withstanding Voltage.

Insulation Resistance: No less than 7500 M Ω .

Capacitance: Change not to exceed 4% of the nominal value or one picofarad, whichever is greater.

Temperature Cycling Test Conditions

Steps	Temp ($^\circ\text{C}$)	Interval (Minutes)
1	$-55 + 0$ -3	30
2	$25 + 10$ -5	10 to 15
3	$125 + 3$ -0	30
4	$25 + 10$ -5	10 to 15

Immersion Test Conditions

•Number of cycles: 2

•Duration of each immersion: 15 minutes

•Immersion bath: Saturated solution of sodium chloride and water

•Temp. of hot bath: $65 - 0 + 5^\circ\text{C}$

•Temp. of cold bath: $25 - 0 + 10^\circ\text{C}$

Life Test: Subject all capacitors to a temperature of 55°C for 48 hours. Then subject units cast in rectangular cases (Types 271, 272, and 273) to a 60-Hz rms voltage equal to the rated peak voltage for 250 hours. Subject units cast in cylindrical cases (Types 291, 292, 293, and 294) to a 60-Hz rms voltage equal to 90% of the rated peak voltage for 250 hours. In both tests, maintain the temperature at 125°C . After test, the capacitors will meet these requirements:

Withstanding Voltage: As specified under Withstanding Voltage.

Insulation Resistance: No less than 7500 M Ω .

Capacitance Change: Within the limits given in the table below or one picofarad, whichever is greater.

Characteristic	Maximum Cap.
B	$\pm 8\%$
C	$\pm 3\%$
D	$\pm 3\%$
E	$\pm 3\%$

In addition, the capacitor must show no visual damage and the markings must be legible.