

Type PD, Leak-Free Motor Run and Power Supply Capacitors

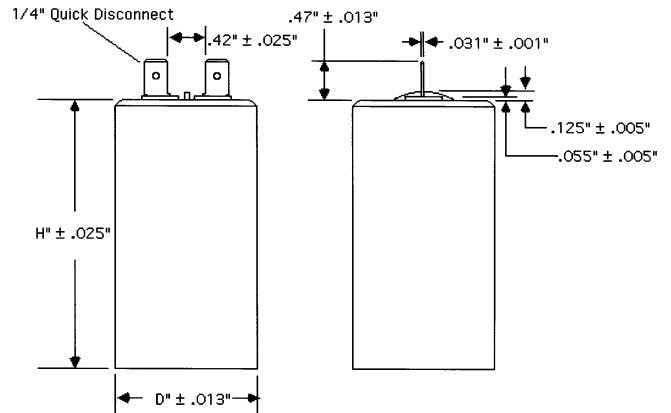

Segmented Metallized Polypropylene Applications

Protect your equipment and the environment with Type PD capacitors. They're UL approved and meet EIA standards for motor-run and general purpose AC applications. These plastic cased, oil-free capacitors use segmented metallized film to ensure safe operation with no potential for messy or hazardous oil leaks.



Highlights

- Dry, epoxy filled construction. No oil.
- Plastic case: (corrosion free, dent free)
- 60,000 h life at rated voltage and temperature
- Voltage ratings: (240, 370, 440) Vac
- Capacitance range: 3.0 μ F to 70.0 μ F
- Capacitance tolerance: $\pm 10\%$
- Dissipation factor: $<0.15\%$ @ 120 Hz
- Temperature range: -55°C to 70°C
- Protected: UL 810 approved
- Environmentally compatible
- Terminals: 1/4" Quick connect, 1 blade per terminal. Optional 2 blades per terminal.

High-Voltage and Motor Capacitors

| Cap. (μ F) Ratings | Catalog Number | D (inches) | H (inches) |
|-------------------------|----------------|------------|------------|
| 240 Vac | | | |
| 3.0 | PDA24U305M24 | 1.18 | 2.25 |
| 4.0 | PDA24U405M24 | 1.18 | 2.25 |
| 5.0 | PDA24U505M24 | 1.18 | 2.25 |
| 6.0 | PDA24U605M24 | 1.18 | 2.25 |
| 7.5 | PDA24U755M2C | 1.18 | 2.75 |
| 10.0 | PDB24U106M2C | 1.58 | 2.75 |
| 12.5 | PDB24U1255M2C | 1.58 | 2.75 |
| 15.0 | PDB24U156M2C | 1.58 | 2.75 |
| 17.5 | PDB24U1755M2C | 1.58 | 2.75 |
| 20.0 | PDB24U206M3C | 1.58 | 3.75 |
| 25.0 | PDB24U256M3C | 1.58 | 3.75 |
| 30.0 | PDB24U306M3C | 1.58 | 3.75 |
| 35.0 | PDC24U356M3C | 1.77 | 3.75 |
| 40.0 | PDC24U406M3C | 1.77 | 3.75 |
| 45.0 | PDC24U456M4B | 1.77 | 4.70 |
| 50.0 | PDC24U506M4B | 1.77 | 4.70 |
| 55.0 | PDC24U556M4B | 1.77 | 4.70 |
| 60.0 | PDD24U606M4B | 1.97 | 4.70 |
| 65.0 | PDD24U656M4B | 1.97 | 4.70 |
| 70.0 | PDD24U706M4B | 1.97 | 4.70 |

| Cap. (μ F) Ratings | Catalog Number | D (inches) | H (inches) |
|-------------------------|----------------|------------|------------|
| 370 Vac | | | |
| 3.0 | PDA37U305M24 | 1.18 | 2.25 |
| 4.0 | PDA37U405M24 | 1.18 | 2.25 |
| 5.0 | PDA37U505M2C | 1.18 | 2.75 |
| 6.0 | PDA37U605M2C | 1.18 | 2.75 |
| 7.5 | PDB37U755M2C | 1.58 | 2.75 |
| 10.0 | PDB37U106M2C | 1.58 | 2.75 |
| 12.5 | PDB37U1255M2C | 1.58 | 2.75 |
| 15.0 | PDB37U156M3C | 1.58 | 3.75 |
| 17.5 | PDB37U1755M3C | 1.58 | 3.75 |
| 20.0 | PDB37U206M3C | 1.58 | 3.75 |
| 25.0 | PDC37U256M3C | 1.77 | 3.75 |
| 30.0 | PDC37U306M4B | 1.77 | 4.70 |
| 35.0 | PDC37U356M4B | 1.77 | 4.70 |
| 40.0 | PDC37U406M4B | 1.77 | 4.70 |
| 45.0 | PDD37U456M4B | 1.97 | 4.70 |
| 50.0 | PDD37U506M4B | 1.97 | 4.70 |

| Cap. (μ F) Ratings | Catalog Number | D (inches) | H (inches) |
|-------------------------|----------------|------------|------------|
| 440 Vac | | | |
| 3.0 | PDA44U305M24 | 1.18 | 2.25 |
| 4.0 | PDA44U405M2C | 1.18 | 2.75 |
| 5.0 | PDA44U505M2C | 1.18 | 2.75 |
| 6.0 | PDB44U605M2C | 1.58 | 2.75 |
| 7.5 | PDB44U755M2C | 1.58 | 2.75 |
| 10.0 | PDB44U106M2C | 1.58 | 2.75 |
| 12.5 | PDB44U1255M3C | 1.58 | 3.75 |
| 15.0 | PDB44U156M3C | 1.58 | 3.75 |
| 17.5 | PDC44U1755M3C | 1.77 | 3.75 |
| 20.0 | PDC44U206M3C | 1.77 | 3.75 |
| 25.0 | PDC44U256M4B | 1.77 | 4.70 |
| 30.0 | PDC44U306M4B | 1.77 | 4.70 |
| 35.0 | PDD44U356M4B | 1.97 | 4.70 |

1605 East Rodney French Blvd.
New Bedford, MA 02744
(508) 996-8564, Fax (508) 996-3830
<http://www.cornell-dubilier.com>
E-mail: cdenb@cornell-dubilier.com

CDE **CORNELL DUBILIER**

Your Source For Capacitor Solutions

Service Life

The service life for this series is 60,000 hours of operating life with a 94% survival rate when operated at full voltage, 60 Hz, and rated ambient temperature. AC capacitors are frequently used at voltages and ambient temperatures other than rated conditions. Service life may be estimated under specific conditions of temperature and voltage by using the curves as shown to the right.

Protective System

CDE's segmented, metallized electrode system protects Type PD capacitors from short-circuit failures. Each segment is connected by "fuses" (part of metallization pattern.) If fault occurs within a segment, the fuses open causing the segment to become isolated. No case expansion is necessary. This protective system provides long life and reliable operation. This system complies with UL810 for 10,000 amp fault current protection.

Mounting Hardware

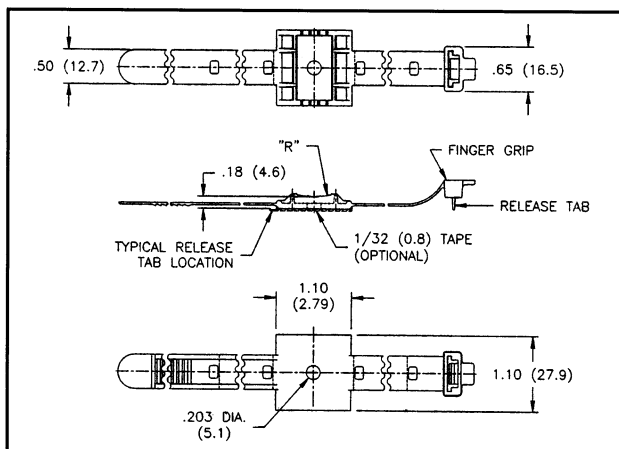

| Case Code | Capacitor Diameter | Bracket |
|-----------|--------------------|-----------|
| PDA | 1.18 | PDUMS2445 |
| PDB | 1.58 | PDUMS3245 |
| PDC | 1.77 | PDUMS3245 |
| PDD | 1.97 | PDUMS3245 |

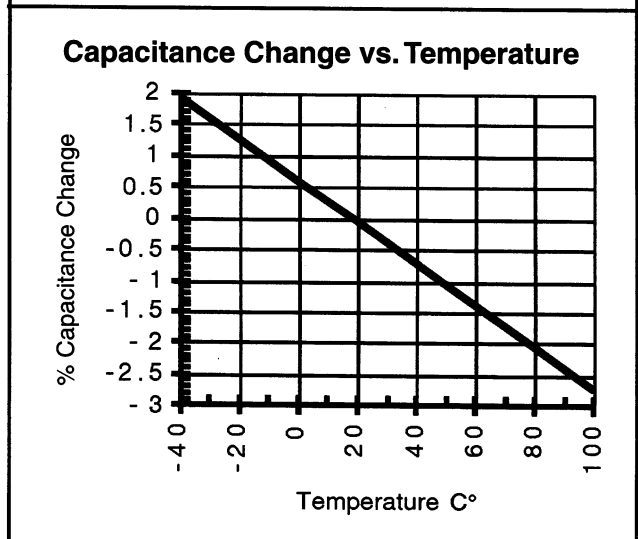
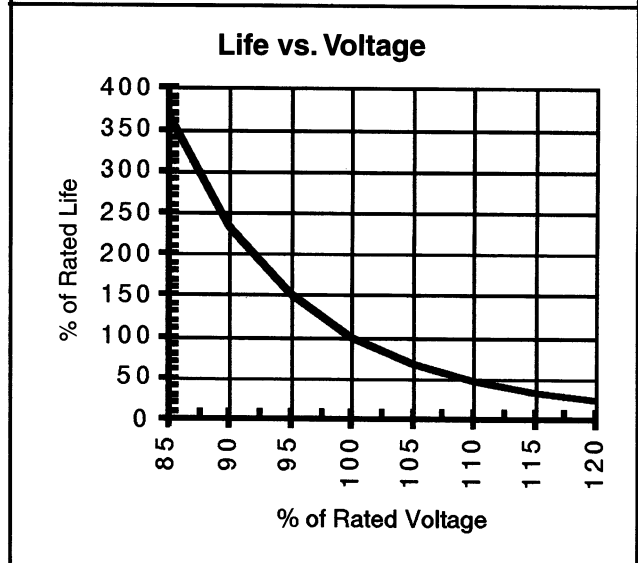
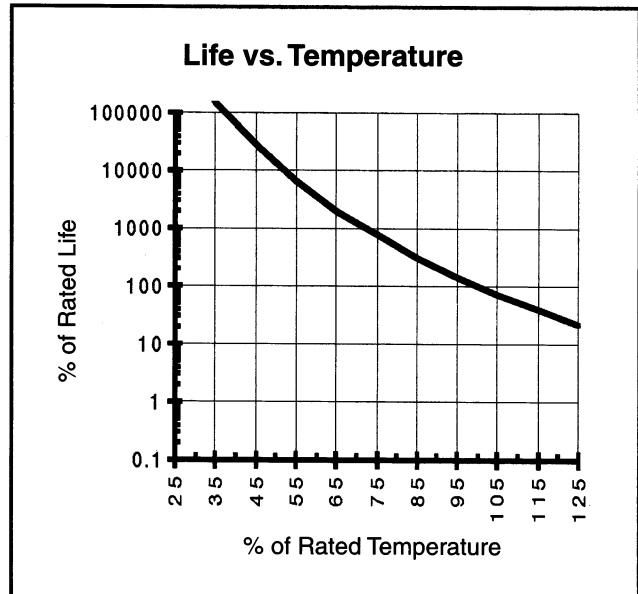

High-Voltage and Motor Capacitors

Type SM Motor-Run and Power Supply Capacitors



Metallized Polypropylene

Applications

Motor Run Capacitors — provide starting torque and power factor correction for split phase motors typically used in refrigeration and air conditioning.

Power Supply Capacitors — are used in power supply circuits to provide noise suppression, voltage regulation, and line current reduction.

Highlights

- Voltage range: 240 to 660 Vac
- Capacitance range: .5 to 120 μF
- Temperature range: -40°C to 70°C , 90°C avail.
- Capacitance tolerance: $\pm 10\%$ standard tolerance; $\pm 3\%$ available.
- Self healing
- Fault Current Protection up to 10,000 amps AFC
- Low energy consumption. Dissipation factor $< 0.1\%$
- 2-tine, 1/4" quick connect lug terminals are standard (4 bladed available)
- Meet requirements of EIA 456A
- UL recognized file No. E56959
- CSA certified file No. LR075387/LR700632

High-Voltage and Motor Capacitors

Service Life Objective

The service life objective for this series is 60,000 hours of operating life with a 94% survival rate when operated at full voltage, 60 Hz, and rated ambient temperature. AC capacitors are frequently used at voltages and ambient temperatures other than rated conditions. Service life may be estimated under specific conditions of temperature and voltage by using the curves as shown to the right.

Capacitance vs. Temperature

The *Capacitance vs. Temperature* curve may be used to determine the capacitance change as a function of temperature. Capacitance varies by no more than $\pm 3\%$ over the operating temperature range.

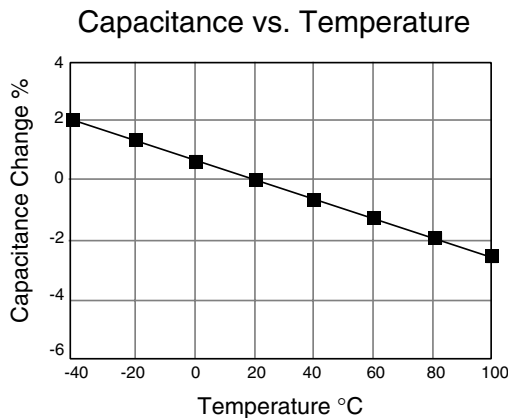
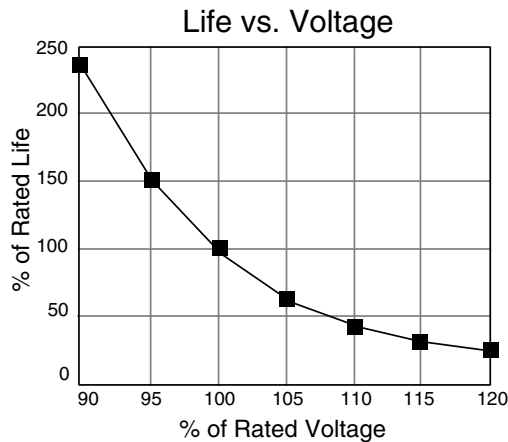
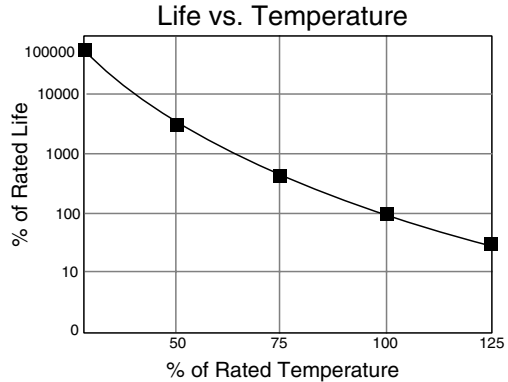

Type SM Motor-Run and Power Supply Capacitors

Type SM – Oval Case Style

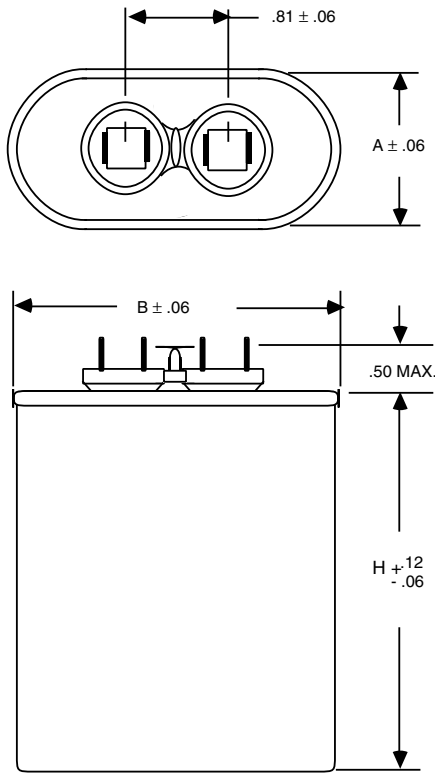

Case Code

| Case Code | Dimensions (Inches) | | |
|-----------|---------------------|------|-----------|
| | A | B | H |
| KK | 1.31 | 2.16 | see table |
| KT | 1.91 | 2.91 | see table |
| KB | 1.97 | 3.66 | see table |

| Cap. (μF) | Stock Items | Catalog Number | Case Code | H (inches) |
|--------------------------------------|-------------|----------------|-----------|------------|
| 240 Vac 70°C Case Temperature | | | | |
| 4.0 | | KKSM24U405M23 | KK | 2.19 |
| 5.0 | | KKSM24U505M23 | KK | 2.19 |
| 6.0 | | KKSM24U605M23 | KK | 2.19 |
| 7.5 | | KKSM24U755M23 | KK | 2.19 |
| 10.0 | | KKSM24U106M23 | KK | 2.19 |
| 15.0 | | KKSM24U156M2B | KK | 2.69 |
| 20.0 | | KKSM24U206M32 | KK | 3.13 |
| 25.0 | | KTSM24U256M2B | KT | 2.69 |
| 30.0 | | KTSM24U306M2B | KT | 2.69 |
| 35.0 | | KTSM24U356M2B | KT | 2.69 |
| 40.0 | | KTSM24U406M32 | KT | 3.13 |
| 45.0 | | KTSM24U456M32 | KT | 3.13 |
| 50.0 | | KTSM24U506M32 | KT | 3.13 |
| 60.0 | | KTSM24U606M3E | KT | 3.88 |
| 70.0 | | KTSM24U706M3E | KT | 3.88 |

| Cap. (μF) | Stock Items | Catalog Number | Case Code | H (inches) |
|--------------------------------------|-------------|----------------|-----------|------------|
| 370 Vac 70°C Case Temperature | | | | |
| 2.0 | S | KKSM37U205M18 | KK | 1.50 |
| 2.0 | S | KKSM37U205M23 | KK | 2.19 |
| 3.0 | S | KKSM37U305M18 | KK | 1.50 |
| 3.0 | S | KKSM37U305M23 | KK | 2.19 |
| 4.0 | S | KKSM37U405M18 | KK | 1.50 |
| 4.0 | S | KKSM37U405M23 | KK | 2.19 |
| 5.0 | S | KKSM37U505M18 | KK | 1.50 |
| 5.0 | S | KKSM37U505M23 | KK | 2.19 |
| 6.0 | S | KKSM37U605M18 | KK | 1.50 |
| 6.0 | S | KKSM37U605M23 | KK | 2.19 |
| 7.5 | S | KKSM37U755M23 | KK | 2.19 |
| 10.0 | S | KKSM37U106M2B | KK | 2.69 |
| 12.5 | S | KKSM37U1255M32 | KK | 3.13 |
| 15.0 | S | KKSM37U156M3E | KK | 3.88 |
| 17.5 | S | KTSM37U1755M2B | KT | 2.69 |
| 20.0 | | KKSM37U206M3E | KK | 3.88 |
| 20.0 | S | KTSM37U206M2B | KT | 2.69 |
| 25.0 | S | KTSM37U256M2B | KT | 2.69 |
| 30.0 | S | KTSM37U306M32 | KT | 3.13 |
| 35.0 | S | KTSM37U356M32 | KT | 3.13 |
| 40.0 | S | KTSM37U406M3E | KT | 3.88 |
| 45.0 | S | KTSM37U456M3E | KT | 3.88 |
| 45.0 | | KBSM37U456M3E | KB | 3.88 |
| 50.0 | S | KTSM37U506M3E | KT | 3.88 |
| 50.0 | S | KBSM37U506M3E | KB | 3.88 |
| 440 Vac 70°C Case Temperature | | | | |
| 2.0 | S | KKSM44U205M23 | KK | 2.19 |
| 3.0 | S | KKSM44U305M23 | KK | 2.19 |
| 4.0 | S | KKSM44U405M23 | KK | 2.19 |
| 5.0 | S | KKSM44U505M23 | KK | 2.19 |
| 6.0 | S | KKSM44U605M2B | KK | 2.69 |
| 7.5 | S | KKSM44U755M32 | KK | 3.13 |
| 10.0 | S | KKSM44U106M3E | KK | 3.88 |
| 15.0 | S | KKSM44U156M3E | KK | 3.88 |
| 15.0 | S | KTSM44U156M2B | KT | 2.69 |
| 20.0 | S | KTSM44U206M3E | KT | 3.88 |
| 25.0 | S | KTSM44U256M3E | KT | 3.88 |
| 30.0 | S | KTSM44U306M3E | KT | 3.88 |
| 35.0 | S | KBSM44U356M3E | KB | 3.88 |
| 40.0 | S | KBSM44U406M3E | KB | 3.88 |
| 45.0 | S | KBSM44U456M3E | KB | 3.88 |
| 50.0 | S | KBSM44U506M3E | KB | 3.88 |
| 55.0 | S | KBSM44U556M44 | KB | 4.25 |
| 60.0 | S | KBSM44U606M44 | KB | 4.25 |

High-Voltage and Motor Capacitors

Type SM Motor-Run and Power Supply Capacitors

| Cap. (μF) | Stock Items | Catalog Number | Case Code | H (inches) |
|---------------------------------------|-------------|----------------|-----------|------------|
| 480 Vac 70 °C Case Temperature | | | | |
| 4.0 | | KKSM48U405M23 | KK | 2.19 |
| 5.0 | | KKSM48U505M32 | KK | 3.13 |
| 6.0 | | KKSM48U605M32 | KK | 3.13 |
| 7.5 | | KKSM48U755M32 | KK | 3.13 |
| 10.0 | | KKSM48U106M32 | KK | 3.13 |
| 15.0 | | KTSM48U156M32 | KT | 3.13 |
| 20.0 | | KTSM48U206M3E | KT | 3.88 |
| 25.0 | | KTSM48U256M3E | KT | 3.88 |
| 30.0 | | KTSM48U306M3E | KT | 3.88 |
| 40.0 | | KBSM48U406M3E | KB | 3.88 |
| 660 Vac 70 °C Case Temperature | | | | |
| 1.0 | | KKSM66U105M23 | KK | 2.19 |
| 2.0 | S | KKSM66U205M23 | KK | 2.19 |
| 3.0 | S | KKSM66U305M23 | KK | 2.19 |
| 4.0 | S | KKSM66U405M2B | KK | 2.69 |
| 5.0 | S | KKSM66U505M32 | KK | 3.13 |
| 6.0 | S | KKSM66U605M3E | KK | 3.88 |
| 8.0 | S | KKSM66U805M3E | KK | 3.88 |
| 8.0 | S | KTSM66U805M32 | KT | 3.13 |
| 10.0 | S | KKSM66U106M3E | KK | 3.88 |
| 10.0 | S | KTSM66U106M32 | KT | 3.13 |
| 12.0 | S | KTSM66U126M32 | KT | 3.13 |
| 15.0 | S | KTSM66U156M3E | KT | 3.88 |
| 18.0 | S | KTSM66U186M3E | KT | 3.88 |
| 18.0 | S | KBSM66U186M3E | KB | 3.88 |
| 20.0 | S | KBSM66U206M3E | KB | 3.88 |
| 25.0 | S | KBSM66U256M3E | KB | 3.88 |
| 30.0 | S | KBSM66U306M3E | KB | 3.88 |
| 35.0 | | KBSM66U356M3E | KB | 3.88 |
| 40.0 | | KBSM66U406M44 | KB | 4.25 |



High-Voltage and Motor Capacitors



Options

- Tinplated steel cans are standard. Aluminum cases are available upon request.
- Tighter capacitance tolerances such as $\pm 3\%$ or $\pm 6\%$ are available.
- $+90^\circ\text{C}$ ratings are available for HID lighting and power supply applications.
- Discharge resistors are available.
- Special terminal lugs such as 4 tines per terminal or 2 tines plus 1 fork lug available.
- Dual capacitance values are available for 370 Vac and 440 Vac applications.

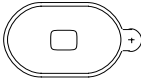
Accessories for Oval Capacitors

Insulating Terminal Boots
UL 465 Listed

44603

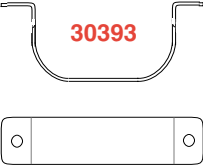

32108-2

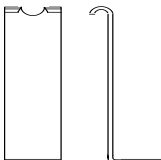

Wrap Around Bracket

| Case Code | Bracket |
|-----------|----------|
| KK | 30393-5 |
| KT | 30393-9 |
| KB | 30393-10 |

End Mount Footed Bracket (2 required)
30434

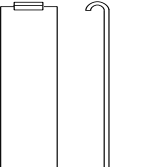

| Case Height | Bracket |
|-------------|----------|
| 2.19 | 30434-34 |
| 2.69 | 30434-42 |
| 3.13 | 30434-49 |
| 3.88 | 30434-61 |
| 4.25 | 30434-67 |

Side Mount Footed Bracket (2 required)
31762

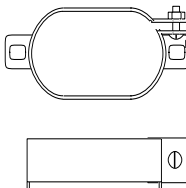
| Case Height | Bracket |
|-------------|----------|
| 2.19 | 31762-45 |
| 2.69 | 31762-47 |
| 3.13 | 31762-49 |
| 3.88 | 31762-18 |
| 4.25 | 31762-52 |

Universal Mounting Brackets 32107

| Case Code | Bracket |
|-----------|---------|
| KK | 32107-1 |
| KT | 32107-2 |
| KB | 32107-3 |



1605 East Rodney French Blvd.
 New Bedford, MA 02744
 (508) 996-8564, Fax (508) 996-3830
<http://www.cornell-dubilier.com>
 E-mail: cdenb@cornell-dubilier.com

CDE **CORNELL DUBILIER**
 Your Source For Capacitor Solutions

6.006

Type SM Motor-Run and Power Supply Capacitors

Type SM - Round Case Style

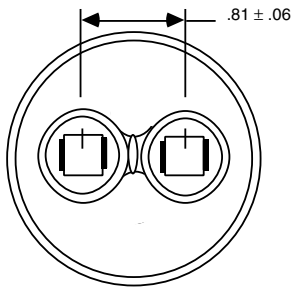

Case Code

| Case Code | D (inches) | H |
|-----------|------------|-----------|
| P | 1.87 | see table |
| S | 2.12 | see table |
| T | 2.62 | see table |

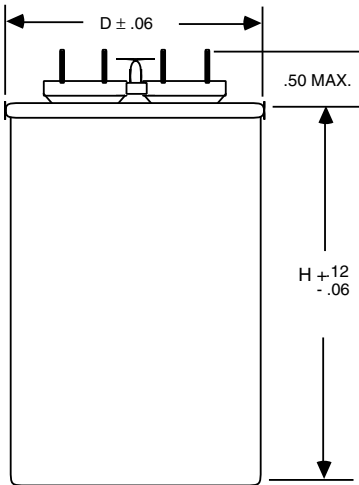

Hardware for Round Capacitors

Wrap Around Bracket

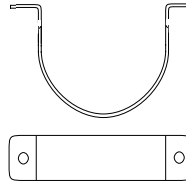

| Case Code | Bracket |
|-----------|----------|
| P | 30393-23 |
| S | 30393-24 |
| T | 30393-25 |

3 Footed Round Mounting Bracket

| Case Code | Bracket |
|-----------|----------|
| P | 32107-6A |
| S | 32107-7A |
| T | 32107-8A |

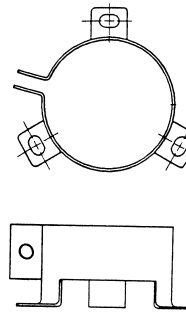

2 Footed Round Mounting Bracket

| Case Code | Bracket |
|-----------|---------|
| P | 32107-6 |
| S | 32107-7 |
| T | 32107-8 |

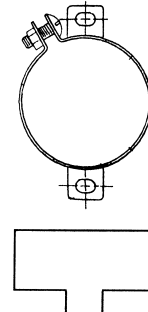

| Cap. (μF) | Stock Items | Catalog Number | Case Code | H (inches) |
|---------------------------------------|-------------|----------------|-----------|------------|
| 370 Vac 70 °C Case Temperature | | | | |
| 2.0 | | SMP37U205M24 | P | 2.25 |
| 3.0 | | SMP37U305M24 | P | 2.25 |
| 4.0 | S | SMP37U405M24 | P | 2.25 |
| 5.0 | | SMP37U505M24 | P | 2.25 |
| 6.0 | | SMP37U605M24 | P | 2.25 |
| 7.5 | | SMP37U755M24 | P | 2.25 |
| 10.0 | S | SMP37U106M24 | P | 2.25 |
| 12.5 | S | SMP37U1255M24 | P | 2.25 |
| 15.0 | S | SMP37U156M2E | P | 2.88 |
| 17.5 | | SMP37U1755M2E | P | 2.88 |
| 20.0 | S | SMP37U206M2E | P | 2.88 |
| 25.0 | S | SMP37U256M2E | P | 2.88 |
| 30.0 | S | SMP37U306M2E | P | 2.88 |
| 35.0 | S | SMS37U356M2E | S | 2.88 |
| 40.0 | S | SMS37U406M2E | S | 2.88 |
| 45.0 | | SMS37U456M3C | S | 3.75 |
| 50.0 | S | SMS37U506M3C | S | 3.75 |
| 55.0 | S | SMS37U556M3C | S | 3.75 |
| 60.0 | S | SMT37U606M3C | T | 3.75 |
| 65.0 | | SMT37U656M3C | T | 3.75 |
| 70.0 | | SMT37U706M3C | T | 3.75 |
| 75.0 | | SMT37U756M3C | T | 3.75 |
| 80.0 | S | SMT37U806M3C | T | 3.75 |

| Cap. (μF) | Stock Items | Catalog Number | Case Code | H (inches) |
|---------------------------------------|-------------|----------------|-----------|------------|
| 370 Vac 70 °C (cont'd) | | | | |
| 90.0 | | SMT37U906M3C | T | 3.75 |
| 100.0 | | SMT37U107M44 | T | 4.25 |
| 440 Vac 70 °C Case Temperature | | | | |
| 2.0 | | SMP44U205M24 | P | 2.25 |
| 3.0 | | SMP44U305M24 | P | 2.25 |
| 4.0 | | SMP44U405M24 | P | 2.25 |
| 5.0 | | SMP44U505M24 | P | 2.25 |
| 6.0 | | SMP44U605M24 | P | 2.25 |
| 7.5 | S | SMP44U755M2E | P | 2.88 |
| 10.0 | S | SMP44U106M2E | P | 2.88 |
| 12.5 | S | SMP44U1255M2E | P | 2.88 |
| 15.0 | S | SMP44U156M2E | P | 2.88 |
| 17.5 | | SMP44U1755M2E | P | 2.88 |
| 20.0 | S | SMP44U206M2E | P | 2.88 |
| 25.0 | | SMS44U256M3C | S | 3.75 |
| 30.0 | S | SMS44U306M3C | S | 3.75 |
| 35.0 | | SMT44U356M2E | T | 2.88 |
| 40.0 | | SMT44U406M3C | T | 3.75 |
| 45.0 | | SMT44U456M3C | T | 3.75 |
| 50.0 | | SMT44U506M3C | T | 3.75 |
| 55.0 | | SMT44U556M44 | T | 4.25 |
| 60.0 | S | SMT44U606M44 | T | 4.25 |

High-Voltage and Motor Capacitors

Type ETW Motor Start Capacitors



Type ETW – Non Polarized Aluminum Electrolytic

Application

AC Motor Start capacitors provide small AC motors with starting torque. They are designed for intermittent AC duty. Type ETW capacitors are provided with a pressure safety vent and are furnished in phenolic cases.

Highlights

- Voltage range: 125 to 330 Vac
- Capacitance range: 21 to 1200 μ F
- 50,000 starts minimum
- Temperature range: -40°C to 65°C
- Operating frequency: 50-60 Hz
- Meets EIA RS463 Type II
- 2-bladed quick connects; standard terminations
- Specify "R" at end of part number for 15,000 ohm, 2 Watt, bleeder resistor.

High-Voltage and Motor Capacitors

| Cap. μ F | Stock Items | Catalog Number | Case Dimensions Inches | | |
|----------------|-------------|----------------|------------------------|-------|-------|
| | | | D | L | C |
| 125 Vac | | | | | |
| 21-25 | S | ETW21-125-N1 | 1.437 | 2.750 | 0.500 |
| 25-30 | S | ETW25-125-N1 | 1.437 | 2.750 | 0.500 |
| 30-36 | S | ETW30-125-N1 | 1.437 | 2.750 | 0.500 |
| 36-43 | S | ETW36-125-N1 | 1.437 | 2.750 | 0.500 |
| 43-52 | S | ETW43-125-N1 | 1.437 | 2.750 | 0.500 |
| 53-64 | S | ETW53-125-N1 | 1.437 | 2.750 | 0.500 |
| 64-77 | S | ETW64-125-N1 | 1.437 | 2.750 | 0.500 |
| 72-86 | S | ETW72-125-N1 | 1.437 | 2.750 | 0.500 |
| 88-106 | S | ETW88-125-N1 | 1.437 | 2.750 | 0.500 |
| 108-130 | S | ETW108-125-N1 | 1.437 | 2.750 | 0.500 |
| 124-149 | S | ETW124-125-N1 | 1.437 | 2.750 | 0.500 |
| 130-156 | S | ETW130-125-N1 | 1.437 | 2.750 | 0.500 |
| 145-174 | S | ETW145-125-N1 | 1.437 | 2.750 | 0.500 |
| 161-193 | S | ETW161-125-N1 | 1.437 | 2.750 | 0.500 |
| 189-227 | S | ETW189-125-N1 | 1.437 | 2.750 | 0.500 |
| 200-240 | S | ETW200-125-N1 | 1.437 | 2.750 | 0.500 |
| 216-259 | S | ETW216-125-N1 | 1.437 | 2.750 | 0.500 |
| 233-280 | S | ETW233-125-N1 | 1.437 | 2.750 | 0.500 |
| 243-292 | S | ETW243-125-N1 | 1.437 | 2.750 | 0.500 |
| 270-324 | S | ETW270-125-N1 | 1.437 | 2.750 | 0.500 |
| 300-360 | S | ETW300-125-N1 | 1.437 | 2.750 | 0.500 |
| 324-389 | S | ETW324-125-N1 | 1.437 | 2.750 | 0.500 |
| 340-408 | S | ETW340-125-N2 | 1.437 | 3.375 | 0.500 |

| Cap. μ F | Stock Items | Catalog Number | Case Dimensions Inches | | |
|-------------------------|-------------|----------------|------------------------|-------|-------|
| | | | D | L | C |
| 125 Vac (cont'd) | | | | | |
| 378-454 | S | ETW378-125-N2 | 1.437 | 3.375 | 0.500 |
| 400-480 | S | ETW400-125-N2 | 1.437 | 3.375 | 0.500 |
| 430-516 | S | ETW430-125-N2 | 1.437 | 3.375 | 0.500 |
| 460-552 | S | ETW460-125-N2 | 1.437 | 3.375 | 0.500 |
| 540-648 | S | ETW540-125-N4 | 1.812 | 3.375 | 0.625 |
| 590-708 | S | ETW590-125-N4 | 1.812 | 3.375 | 0.625 |
| 708-850 | S | ETW708-125-N4 | 1.812 | 3.375 | 0.625 |
| 829-995 | S | ETW829-125-N4 | 1.812 | 3.375 | 0.625 |
| 1000-1200 | S | ETW1000-125-N7 | 2.062 | 4.375 | 0.875 |
| 165 Vac | | | | | |
| 108-130 | | ETW108-165-N1 | 1.437 | 2.750 | 0.500 |
| 145-174 | | ETW145-165-N1 | 1.437 | 2.750 | 0.500 |
| 161-193 | | ETW161-165-N1 | 1.437 | 2.750 | 0.500 |
| 189-227 | | ETW189-165-N2 | 1.437 | 3.375 | 0.500 |
| 216-260 | | ETW216-165-N4 | 1.812 | 3.375 | 0.625 |
| 233-280 | | ETW233-165-N4 | 1.812 | 3.375 | 0.625 |
| 243-292 | | ETW243-165-N4 | 1.812 | 3.375 | 0.625 |
| 270-324 | | ETW270-165-N4 | 1.812 | 3.375 | 0.625 |
| 324-390 | | ETW324-165-N4 | 1.812 | 3.375 | 0.625 |
| 340-408 | | ETW340-165-N4 | 1.812 | 3.375 | 0.625 |
| 378-454 | | ETW378-165-N4 | 1.812 | 3.375 | 0.625 |
| 400-480 | | ETW400-165-N4 | 1.812 | 3.375 | 0.625 |
| 430-516 | | ETW430-165-N4 | 1.812 | 3.375 | 0.625 |

Type ETW Motor Start Capacitors

| CAP μF | Stock Items | Catalog Number | Case Dimensions Inches | | |
|----------------|----------------|-------------------|---------------------------|-------|-------|
| | | | D | L | C |
| 250 Vac | | | | | |
| 21-25 | S | ETW21-250-N1 | 1.437 | 2.750 | 0.500 |
| 25-30 | S | ETW25-250-N1 | 1.437 | 2.750 | 0.500 |
| 30-36 | S | ETW30-250-N1 | 1.437 | 2.750 | 0.500 |
| 36-43 | S | ETW36-250-N1 | 1.437 | 2.750 | 0.500 |
| 43-52 | S | ETW43-250-N1 | 1.437 | 2.750 | 0.500 |
| 53-64 | S | ETW53-250-N1 | 1.437 | 2.750 | 0.500 |
| 56-72 | S | ETW56-250-N1 | 1.437 | 2.750 | 0.500 |
| 64-77 | S | ETW64-250-N1 | 1.437 | 2.750 | 0.500 |
| 72-86 | S | ETW72-250-N4 | 1.812 | 3.375 | 0.625 |
| 88-106 | S | ETW88-250-N4 | 1.812 | 3.375 | 0.625 |
| 108-130 | S | ETW108-250-N4 | 1.812 | 3.375 | 0.625 |
| 124-149 | S | ETW124-250-N4 | 1.812 | 3.375 | 0.625 |
| 130-156 | S | ETW130-250-N4 | 1.812 | 3.375 | 0.625 |
| 145-174 | S | ETW145-250-N4 | 1.812 | 3.375 | 0.625 |
| 161-193 | S | ETW161-250-N6 | 2.062 | 3.375 | 0.875 |
| 189-227 | S | ETW189-250-N6 | 2.062 | 3.375 | 0.875 |
| 216-259 | S | ETW216-250-N6 | 2.062 | 3.375 | 0.875 |
| 233-280 | S | ETW233-250-N6 | 2.062 | 3.375 | 0.875 |
| 243-292 | S | ETW243-250-N6 | 2.062 | 3.375 | 0.875 |

| CAP μF | Stock Items | Catalog Number | Case Dimensions Inches | | |
|-------------------------|----------------|-------------------|---------------------------|-------|-------|
| | | | D | L | C |
| 250 Vac (cont'd) | | | | | |
| 270-324 | S | ETW270-250-N6 | 2.062 | 3.375 | 0.875 |
| 340-408 | S | ETW340-250-N7 | 2.062 | 4.375 | 0.875 |
| 330 Vac | | | | | |
| 21-25 | S | ETW21-330-N2 | 1.437 | 3.375 | 0.500 |
| 25-30 | S | ETW25-330-N2 | 1.437 | 3.375 | 0.500 |
| 30-36 | S | ETW30-330-N2 | 1.437 | 3.375 | 0.500 |
| 36-43 | S | ETW36-330-N2 | 1.437 | 3.375 | 0.500 |
| 43-52 | S | ETW43-330-N4 | 1.812 | 3.375 | 0.625 |
| 53-64 | S | ETW53-330-N4 | 1.812 | 3.375 | 0.625 |
| 64-77 | S | ETW64-330-N4 | 1.812 | 3.375 | 0.625 |
| 72-86 | S | ETW72-330-N4 | 1.812 | 3.375 | 0.625 |
| 88-106 | S | ETW88-330-N4 | 1.812 | 3.375 | 0.625 |
| 108-130 | S | ETW108-330-N7 | 2.062 | 4.375 | 0.875 |
| 124-149 | S | ETW124-330-N7 | 2.062 | 4.375 | 0.875 |
| 130-156 | S | ETW130-330-N7 | 2.062 | 4.375 | 0.875 |
| 145-174 | S | ETW145-330-N7 | 2.062 | 4.375 | 0.875 |
| 161-193 | S | ETW161-330-N7 | 2.062 | 4.375 | 0.875 |
| 189-227 | S | ETW189-330-N7 | 2.062 | 4.375 | 0.875 |
| 216-259 | S | ETW216-330-N7 | 2.062 | 4.375 | 0.875 |

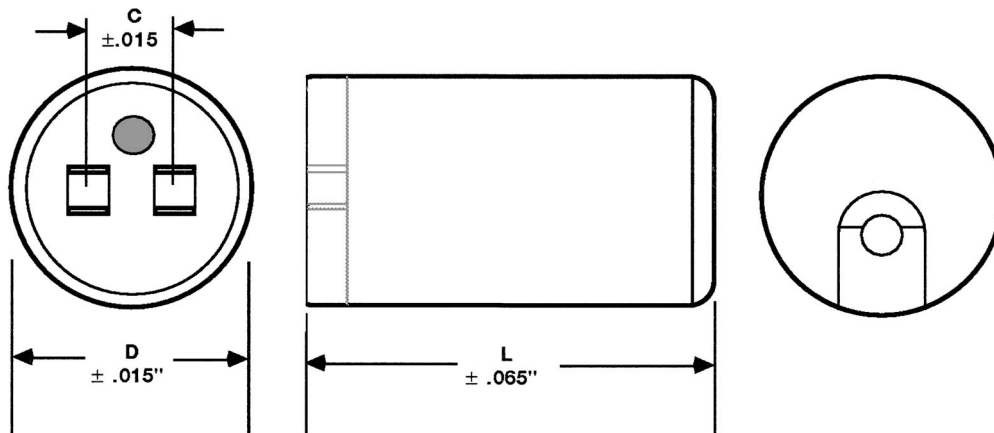

High-Voltage
and
Motor Capacitors

Bracket, Endcap & Capacitor Assembly

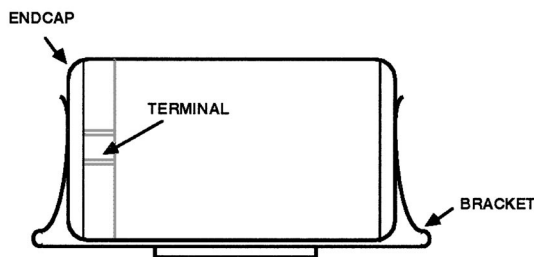

Mounting Hardware

| Case Code | Case Dimensions (inches) | | Optional End Cap | Optional Mounting Bracket |
|-----------|--------------------------|-------|------------------|---------------------------|
| | D | L | | |
| N1 | 1.437 | 2.750 | 30066 | 34946-2 |
| N2 | 1.437 | 3.375 | 30066 | 34946 |
| N4 | 1.812 | 3.375 | 34618-3 | 34946 |
| N6 | 2.062 | 3.375 | 34618-2 | 34946 |
| N7 | 2.062 | 4.375 | 34618-2 | 34946-1 |

* Order both endcap and bracket for mounting



**CORNELL
DUBILIER**

1605 East Rodney French Blvd.
New Bedford, MA 02744
(508) 996-8564, Fax (508) 996-3830
<http://www.cornell-dubilier.com>
E-mail: cdendb@cornell-dubilier.com

Your Source For Capacitor Solutions

Application Guide for Type ETW Motor Start Capacitors

VOLTAGE RATING

The capacitor's rated voltage must be greater than or equal to the average voltage across the capacitor's terminals during the motor starting cycle. This is not the same voltage as the motor line voltage. In addition, the cutoff voltage rating of the capacitor must be greater than or equal to the maximum voltage attained across the terminals of the capacitor in actual service.

The maximum recommended cut-off voltages for the four standard voltage ratings are as follows:

| Rated Voltage (rms) | Maximum Cut-Off Voltage (rms) |
|----------------------------|--------------------------------------|
| 125 | 160 |
| 165 | 210 |
| 250 | 300 |
| 330 | 400 |

These ratings are based on the maximum capacitor temperature of 65 °C.

CAPACITANCE RATING

The capacitance is chosen to give the necessary starting torque to the motor. The minimum capacitance value is the minimum designed capacitance. The maximum capacitance is 20% more than the minimum value.

DUTY CYCLE

The duty cycle should be calculated for each application. It is the ratio of the time the capacitor is on voltage to the total time of one cycle. The duty cycles for the normal performance of standard Type II capacitors are listed in Table A. CDE type ETW capacitors may be used in any intermittent application within their temperature and voltage range where the duty cycle does not exceed that listed in Table A. This is in accordance with the standards in EIA Specification RS-463 for Type II capacitors. If a particular application exceeds the normal duty cycle, but does not exceed the values listed in Table B, an extra performance or Type I capacitor is required.

FREQUENCY

These capacitors are designed for 60 Hz application but may be operated in the range of 47 Hz - 60 Hz without damage provided voltage limitations stated above are observed. For other variations in frequency, contact CDE.

Duty Cycles of Type II

Table A

| Rated Voltage (VAC rms) | Capacitance Rating (µF) | | Duty Cycle | | % Duty Cycle | # of Starts |
|-------------------------|-------------------------|---------|------------|-------------|--------------|-------------|
| | From | To | Secs. (On) | Secs. (Off) | | |
| 125 | 21-25 | 81-106 | 0.75 | 29.25 | 2.500 | 50,000 |
| | 108-130 | 145-174 | 1 | 59 | 1.670 | 50,000 |
| | 161-193 | 233-280 | 1 | 89 | 1.110 | 33,500 |
| | 243-292 | 378-454 | 1 | 119 | 0.833 | 25,000 |
| | 400-480 | 590-708 | 1 | 179 | 0.556 | 16,500 |
| | 645-774 | 800-960 | 1 | 239 | 0.417 | 12,500 |
| 165 | 21-25 | 88-106 | 1 | 59 | 1.670 | 33,500 |
| | 108-130 | 124-149 | 1 | 89 | 1.110 | 33,500 |
| | 130-156 | 216-259 | 1 | 119 | 0.833 | 25,000 |
| | 233-280 | 340-408 | 1 | 179 | 0.556 | 16,500 |
| | 378-454 | 590-708 | 1 | 239 | 0.417 | 12,500 |
| | 21-25 | 30-36 | 1 | 59 | 1.670 | 33,500 |
| 250 | 36-43 | 64-77 | 1 | 89 | 1.110 | 33,500 |
| | 72-86 | 88-106 | 1 | 119 | 0.833 | 25,000 |
| | 108-130 | 189-227 | 1 | 179 | 0.556 | 16,500 |
| | 216-259 | 324-389 | 1 | 239 | 0.417 | 12,500 |
| | 21-25 | 21-25 | 1 | 59 | 1.670 | 33,500 |
| | 25-36 | 30-36 | 1 | 89 | 1.110 | 33,500 |
| 330 | 36-43 | 64-77 | 1 | 119 | 0.833 | 25,000 |
| | 72-86 | 88-106 | 1 | 179 | 0.556 | 16,500 |
| | 108-130 | 130-156 | 1 | 239 | 0.417 | 12,500 |
| | 108-130 | 130-156 | 1 | 239 | 0.417 | 12,500 |

Typical life expectancy is 50,000 cycles for 125V ratings, and 40,000 total cycles for 165, 250 and 330V ratings. The number of cycles shown in the table above are for the convenient test time of 35 days total for all ratings.

Duty Cycles of Type I

Table B

| Rated Voltage (VAC rms) | Capacitance Rating (µF) | Duty Cycle | | % Duty Cycle | # of Starts |
|-------------------------|-------------------------|------------|-------------|--------------|-------------|
| | | Secs. (On) | Secs. (Off) | | |
| 125 | all | 0.75 | 29.25 | 2.500 | 75,000 |
| 165 | all | 1 | 59 | 1.670 | 40,000 |
| 250 | all | 1 | 59 | 1.670 | 40,000 |
| 330 | all | 1 | 59 | 1.670 | 40,000 |

If an application exceeds the duty cycles of Type I, other methods of capacitor selection must be used. Contact CDE, for Engineering assistance.

MOUNTING

Vertical mounting of the capacitor with the terminals up is recommended. However, horizontal mounting is acceptable providing the vent is in the upward position. Vertical mounting with the terminals down is not recommended because the capacitor life may be reduced.

Type OTB DC/AC Dual Rated Capacitors



Type OTB – Paper-Film/Foil

Applications

Use Type OTB capacitors for all normal blocking, filtering and bypass applications where any standard DC capacitor may be used. They may also be used in motor-run and other 60 Hz applications.

Highlights

- Voltage ratings DC/AC: 400/236, 600/330, 1000/440, 1500/660, 2000/700, 2500/800, 3000/950
- Capacitance range: 0.1 μ F to 35.0 μ F
- Capacitance tolerance: \pm 10%
- Temperature range: -55°C to 85°C
- Protected: Pressure sensitive interrupter
- Listed under UL File No. E56959
- CSA Certified file No. LR075387
- Environmentally compatible
- Solder Lug terminations

| Cap. (μ F) | Stock Items | Catalog Number | Case Code | H (inches) |
|---|-------------|----------------|-----------|------------|
| 400 Vdc (236 Vac) – Paper Dielectric | | | | |
| 3.0 | | OTBE305KNPIR | A | 2.13 |
| 4.0 | | OTBE405KNPIR | A | 2.38 |
| 5.0 | | OTBE505KNPIR | A | 2.63 |
| 6.0 | | OTBE605KNPIR | A | 2.88 |
| 8.0 | | OTBE805KNPIR | A | 3.88 |
| 10.0 | | OTBE106KNPIR | A | 4.75 |
| 12.0 | | OTBE126KNPIR | C | 3.13 |
| 15.0 | | OTBE156KNPIR | C | 3.50 |
| 20.0 | | OTBE206KNPIR | C | 4.75 |
| 25.0 | | OTBE256KNPIR | C | 5.75 |
| 30.0 | | OTBE306KNPIR | C | 6.75 |
| 600 Vdc (330 Vac) – Paper Dielectric | | | | |
| 0.50 | | OTBF504KNPIR | A | 2.13 |
| 1.0 | | OTBF105KNPIR | A | 2.13 |
| 2.0 | | OTBF205KNPIR | A | 2.13 |
| 3.0 | | OTBF305KNPIR | A | 2.38 |
| 4.0 | | OTBF405KNPIR | A | 2.63 |
| 5.0 | | OTBF505KNPIR | A | 3.13 |
| 6.0 | | OTBF605KNPIR | A | 3.88 |
| 8.0 | | OTBF805KNPIR | A | 4.75 |
| 10.0 | | OTBF106KNPIR | C | 3.13 |
| 12.0 | | OTBF126KNPIR | C | 3.88 |
| 15.0 | | OTBF156KNPIR | C | 4.25 |
| 20.0 | | OTBF206KNPIR | C | 5.75 |
| 25.0 | | OTBF256KNPIR | C | 6.75 |
| 30.0 | | OTBF306KNPIR | D | 6.25 |
| 35.0 | | OTBF356KNPIR | D | 7.25 |

| Cap. (μ F) | Stock Items | Catalog Number | Case Code | H (inches) |
|---|-------------|----------------|-----------|------------|
| 1000 Vdc (440 Vac) – Paper Dielectric | | | | |
| 0.10 | | OTBG104KNPIR | A | 2.13 |
| 0.25 | S | OTBG254KNPIR | A | 2.13 |
| 0.50 | S | OTBG504KNPIR | A | 2.13 |
| 1.0 | | OTBG105KNPIR | A | 2.13 |
| 2.0 | | OTBG205KNPIR | A | 2.63 |
| 3.0 | | OTBG305KNPIR | A | 3.13 |
| 4.0 | | OTBG405KNPIR | A | 4.25 |
| 5.0 | | OTBG505KNPIR | A | 4.75 |
| 6.0 | | OTBG605KNPIR | C | 3.13 |
| 8.0 | | OTBG805KNPIR | C | 4.25 |
| 10.0 | | OTBG106KNPIR | C | 4.75 |
| 12.0 | | OTBG126KNPIR | C | 5.75 |
| 15.0 | | OTBG156KNPIR | C | 7.25 |
| 20.0 | | OTBG206KNPIR | D | 7.25 |
| 25.0 | | OTBG256KNPIR | D | 9.00 |
| 1500 Vdc (660 Vac) – Film/Paper Dielectric | | | | |
| 0.50 | | OTBH504KNPIR | A | 2.13 |
| 1.0 | S | OTBH105KNPIR | A | 2.13 |
| 2.0 | S | OTBH205KNPIR | A | 3.13 |
| 3.0 | S | OTBH305KNPIR | A | 4.25 |
| 4.0 | | OTBH405KNPIR | C | 3.13 |
| 5.0 | | OTBH505KNPIR | C | 3.50 |
| 6.0 | | OTBH605KNPIR | C | 4.25 |
| 8.0 | | OTBH805KNPIR | C | 5.25 |
| 10.0 | | OTBH106KNPIR | D | 5.25 |
| 12.0 | | OTBH126KNPIR | D | 5.75 |
| 15.0 | | OTBH156KNPIR | D | 6.75 |

High-Voltage and Motor Capacitors

CDE

**CORNELL
DUBILIER**

Your Source For Capacitor Solutions

1605 East Rodney French Blvd.
New Bedford, MA 02744
(508) 996-8564, Fax (508) 996-3830
<http://www.cornell-dubilier.com>
E-mail: cdendb@cornell-dubilier.com

6.0011

Type OTB DC/AC Dual Rated Capacitors

| Cap. (μF) | Stock Items | Catalog Number | Case Code | H (inches) |
|---|-------------|----------------|-----------|------------|
| 2000 Vdc (700 Vac) – Film/Paper Dielectric | | | | |
| 0.10 | | OTBJ104KNPIR | A | 2.13 |
| 0.25 | | OTBJ254KNPIR | A | 2.13 |
| 0.50 | S | OTBJ504KNPIR | A | 2.13 |
| 1.0 | | OTBJ105KNPIR | A | 2.63 |
| 2.0 | | OTBJ205KNPIR | A | 4.25 |
| 3.0 | | OTBJ305KNPIR | C | 3.50 |
| 4.0 | | OTBJ405KNPIR | C | 4.25 |
| 5.0 | | OTBJ505KNPIR | C | 4.75 |
| 6.0 | | OTBJ605KNPIR | C | 5.75 |
| 8.0 | | OTBJ805KNPIR | D | 5.75 |
| 10.0 | | OTBJ106KNPIR | D | 6.75 |
| 2500 Vdc (800 Vac) – Film/Paper Dielectric | | | | |
| 0.50 | | OTBK504KNPIR | A | 2.13 |
| 1.0 | | OTBK105KNPIR | C | 2.88 |
| 2.0 | | OTBK205KNPIR | C | 3.13 |
| 3.0 | | OTBK305KNPIR | C | 4.25 |
| 4.0 | | OTBK405KNPIR | C | 5.75 |
| 5.0 | | OTBK505KNPIR | C | 6.75 |
| 6.0 | | OTBK605KNPIR | D | 5.75 |
| 7.0 | | OTBK705KNPIR | D | 6.75 |
| 8.0 | | OTBK805KNPIR | D | 7.25 |

| Cap. (μF) | Stock Items | Catalog Number | Case Code | H (inches) |
|---|-------------|----------------|-----------|------------|
| 3000 Vdc (950 Vac) – Film/Paper Dielectric | | | | |
| 0.10 | | OTBL104KNPIR | A | 2.13 |
| 0.25 | | OTBL254KNPIR | A | 2.13 |
| 0.50 | | OTBL504KNPIR | C | 2.88 |
| 1.0 | | OTBL105KNPIR | C | 2.88 |
| 2.0 | | OTBL205KNPIR | C | 4.25 |
| 3.0 | | OTBL305KNPIR | C | 5.75 |
| 4.0 | | OTBL405KNPIR | D | 5.75 |
| 5.0 | | OTBL505KNPIR | D | 6.75 |

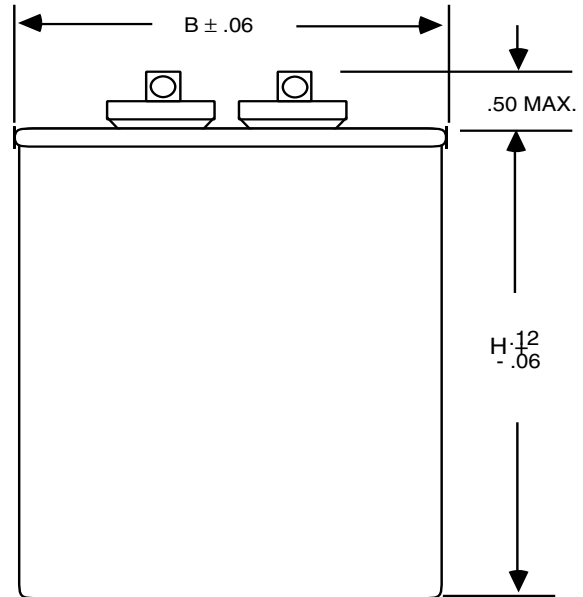
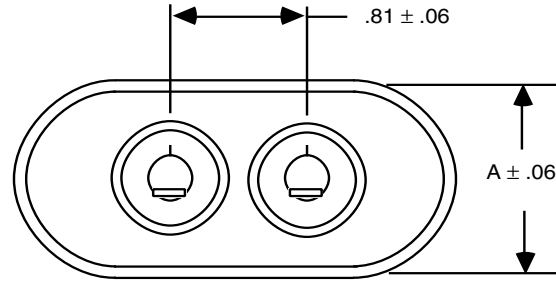

Mounting Hardware

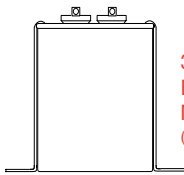

30434
End Mount
(2 required)

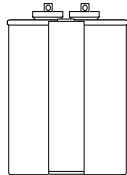

31762
Side Mount
(2 required)

| H (Inches) | End Mount | Side Mount |
|------------|-----------|------------|
| 2.13 | 30434-33 | 31762-45 |
| 2.38 | 30434-37 | 31762-46 |
| 2.63 | 30434-41 | 31762-47 |
| 2.88 | 30434-45 | 31762-48 |
| 3.13 | 30434-49 | 31762-49 |
| 3.50 | 30434-55 | 31762-50 |
| 3.75 | 30434-59 | 31762-83 |
| 3.88 | 30434-61 | 31762-51 |
| 4.25 | 30434-67 | 31762-52 |
| 4.75 | 30434-75 | 31762-54 |
| 5.25 | 30434-83 | 31762-55 |
| 5.75 | 30434-91 | 31762-56 |
| 6.25 | 30434-99 | 31762-59 |
| 6.75 | 30434-107 | 31762-60 |
| 7.25 | 30434-115 | 31762-62 |
| 9.00 | 30434-127 | 31762-78 |

| Case Code | Bracket |
|-----------|----------|
| A | 30393-5 |
| C | 30393-9 |
| D | 30393-10 |

| Case Code | Bracket |
|-----------|---------|
| A | 32107-1 |
| C | 32107-2 |
| D | 32107-3 |



Wrap Around Bracket
30393



Universal Mounting Bracket
32107

6-32 screw and nut

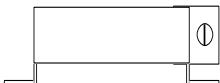

Case Code

| Case Code | Dimensions (Inches) | | |
|-----------|---------------------|------|-----------|
| | A | B | H |
| A | 1.31 | 2.16 | see table |
| C | 1.91 | 2.91 | see table |
| D | 1.97 | 3.66 | see table |

High-Voltage and Motor Capacitors

Type SCR Commutating Capacitors



Type SCR – Film-Paper/Extended Foil Applications

Type SCR capacitors are for SCR (silicon controlled rectifier) commutating applications, requiring high peak and rms current capability. These capacitors are ideal for other high frequency and pulsed applications.

Highlights

- Voltage ratings 200 to 2000 Vpk
- Capacitance range: 0.25 to 50 μF
- Capacitance tolerance: $\pm 10\%$
- Temperature range: -40°C to 65°C
 80°C surface temperature
- 40,000 Hour, 95% minimum survival at full rated temperature and volt-amps
- Conforms to EIA RS401
- 1/4 x 20 threaded studs for high current
- Tinplated steel case standard. Non ferrous covers available for high frequency applications.

| Cap. (μF) | Stock Item | Catalog Number | Case Code | H (inches) | Max VA (65°C) | Max Amps RMS |
|--|------------|----------------|-----------|------------|---------------------------------|--------------|
| 200 Vpk (Paper dielectric) | | | | | | |
| 3.0 | | SCRN201R | A | 2.13 | 400 | 60 |
| 5.0 | | SCRN202R | A | 2.63 | 465 | 60 |
| 10.0 | S | SCRN203R | A | 3.88 | 625 | 60 |
| 15.0 | | SCRN205R | A | 4.75 | 765 | 60 |
| 20.0 | | SCRN206R | B | 4.25 | 875 | 60 |
| 30.0 | | SCRN208R | C | 5.25 | 1200 | 60 |
| 40.0 | | SCRN209R | C | 6.75 | 1500 | 60 |
| 50.0 | | SCRN210R | D | 5.75 | 1590 | 60 |
| 400 Vpk (Film and Paper dielectric) | | | | | | |
| 2.0 | | SCRN211R | A | 2.63 | 790 | 60 |
| 3.0 | | SCRN212R | A | 2.63 | 970 | 60 |
| 5.0 | | SCRN213R | A | 3.88 | 1130 | 60 |
| 10.0 | | SCRN214R | B | 4.75 | 1930 | 60 |
| 15.0 | | SCRN215R | C | 4.75 | 2240 | 60 |
| 20.0 | | SCRN216R | C | 6.25 | 2800 | 60 |
| 30.0 | | SCRN217R | D | 6.75 | 3720 | 60 |
| 40.0 | | SCRN218R | D | 8.00 | 4330 | 60 |
| 50.0 | | SCRN219R | E | 6.25 | 6050 | 100 |
| 600 Vpk (Film and Paper dielectric) | | | | | | |
| 2.0 | | SCRN220R | A | 2.63 | 815 | 60 |
| 3.0 | | SCRN221R | A | 3.13 | 1200 | 60 |
| 5.0 | S | SCRN222R | A | 4.25 | 1420 | 60 |
| 10.0 | S | SCRN224R | C | 4.25 | 2040 | 60 |
| 15.0 | | SCRN226R | C | 5.75 | 2800 | 60 |
| 20.0 | S | SCRN227R | D | 5.75 | 3260 | 60 |
| 25.0 | S | SCRN229R | D | 6.75 | 3720 | 60 |
| 30.0 | | SCRN230R | D | 8.00 | 4330 | 60 |
| 40.0 | | SCRN231R | E | 6.25 | 6060 | 100 |
| 50.0 | | SCRN232R | E | 7.25 | 6850 | 100 |

| Cap. (μF) | Stock Item | Catalog Number | Case Code | H (inches) | Max VA (65°C) | Max Amps RMS |
|---|------------|----------------|-----------|------------|---------------------------------|--------------|
| 600 Vpk (Film dielectric for low-loss) | | | | | | |
| 1.0 | | SCRN262R | A | 2.38 | 2200 | 60 |
| 2.0 | | SCRN263R | A | 2.38 | 2060 | 60 |
| 3.0 | | SCRN264R | A | 3.88 | 3190 | 60 |
| 5.0 | | SCRN265R | A | 4.25 | 4380 | 60 |
| 10.0 | | SCRN266R | C | 4.25 | 6060 | 60 |
| 1000 Vpk (Film and Paper dielectric) | | | | | | |
| 1.0 | S | SCRN233R | A | 2.13 | 790 | 60 |
| 2.0 | S | SCRN234R | A | 3.13 | 1070 | 60 |
| 3.0 | | SCRN235R | A | 3.88 | 1455 | 60 |
| 5.0 | S | SCRN236R | B | 4.25 | 1785 | 60 |
| 10.0 | | SCRN237R | C | 5.75 | 2570 | 60 |
| 15.0 | | SCRN238R | D | 5.75 | 3170 | 60 |
| 20.0 | S | SCRN239R | E | 5.13 | 5200 | 100 |
| 1500 Vpk (Film and Paper dielectric) | | | | | | |
| 0.50 | S | SCRN240R | A | 2.13 | 990 | 60 |
| 1.0 | S | SCRN241R | A | 2.88 | 1240 | 60 |
| 2.0 | S | SCRN242R | B | 3.50 | 1890 | 60 |
| 3.0 | S | SCRN243R | C | 4.25 | 2550 | 60 |
| 5.0 | | SCRN244R | C | 5.75 | 3250 | 60 |
| 10.0 | | SCRN245R | E | 5.13 | 6500 | 100 |
| 2000 Vpk (Film and Paper dielectric) | | | | | | |
| 0.25 | S | SCRN246R | A | 2.13 | 990 | 60 |
| 0.33 | | SCRN257R | A | 2.13 | 1000 | 60 |
| 0.50 | S | SCRN247R | A | 2.63 | 1180 | 60 |
| 1.0 | S | SCRN248R | A | 3.13 | 1300 | 60 |
| 2.0 | | SCRN249R | B | 4.25 | 2230 | 60 |
| 3.0 | | SCRN251R | C | 4.75 | 2800 | 60 |
| 5.0 | S | SCRN253R | D | 5.75 | 4020 | 60 |
| 10.0 | S | SCRN256R | F | 5.75 | 7600 | 100 |

High-Voltage
and
Motor Capacitors

CDE

**CORNELL
DUBILIER**

Your Source For Capacitor Solutions

1605 East Rodney French Blvd.
New Bedford, MA 02744
(508) 996-8564, Fax (508) 996-3830
<http://www.cornell-dubilier.com>
E-mail: cdendb@cornell-dubilier.com

Type SCR Commutating Capacitors

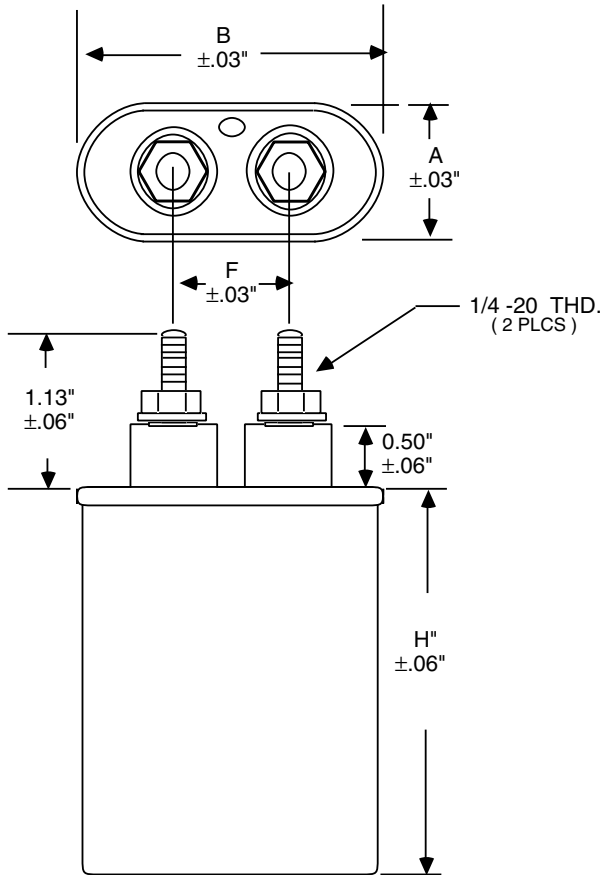

Figure 1

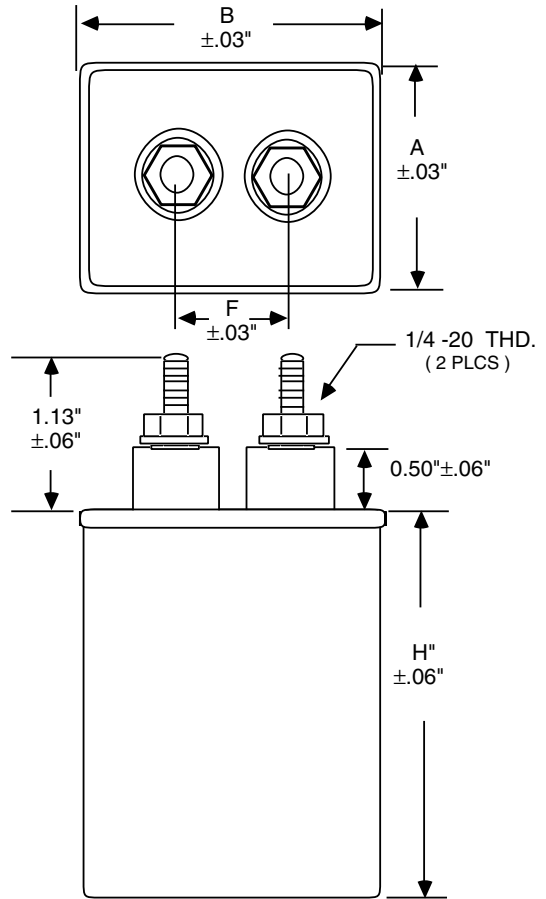

Figure 2

Case Code

| Case Code | Dimensions (inches) | | | | Figure |
|-----------|---------------------|------|------|-----------|--------|
| | A | B | F | H | |
| A | 1.31 | 2.16 | 0.81 | see table | Fig. 1 |
| B | 1.56 | 2.69 | 1.25 | see table | Fig. 1 |
| C | 1.91 | 2.91 | 1.38 | see table | Fig. 1 |
| D | 1.97 | 3.66 | 1.38 | see table | Fig. 1 |
| E | 2.84 | 4.56 | 2.00 | see table | Fig. 2 |
| F | 3.75 | 4.56 | 2.00 | see table | Fig. 2 |

Mounting Hardware

| Case Code | Bracket |
|-----------|----------|
| A | 30393-5 |
| B | 30393-3 |
| C | 30393-9 |
| D | 30393-10 |
| E | - |
| F | - |

| Case Code | Bracket |
|-----------|---------|
| A | 32107-1 |
| B | - |
| C | 32107-2 |
| D | 32107-3 |
| E | - |
| F | - |

Mounting Hardware

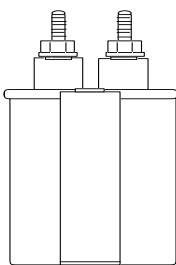

31762
Side
Mount
(2 required)

| H (Inches) | Side Mount |
|------------|------------|
| 2.13 | 31762-45 |
| 2.38 | 31762-46 |
| 2.63 | 31762-47 |
| 2.88 | 31762-48 |
| 3.13 | 31762-49 |
| 3.50 | 31762-50 |
| 3.75 | 31762-83 |
| 3.88 | 31762-51 |
| 4.25 | 31762-52 |
| 4.75 | 31762-54 |
| 5.13 | 31762-132 |
| 5.25 | 31762-55 |
| 5.75 | 31762-56 |
| 6.25 | 31762-59 |
| 6.75 | 31762-60 |
| 7.25 | 31762-62 |
| 8.00 | 31762-63 |
| 9.00 | 31762-78 |

Wrap
Around
Bracket
30393

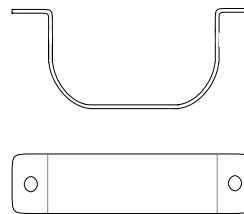

Universal
Mounting
Bracket
32107

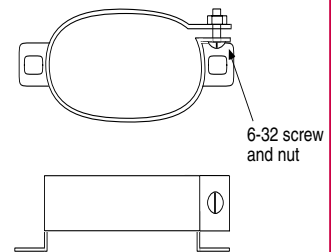

Type SCR Commutating Capacitors

How to Choose a Commutating Capacitor

1. From circuit analysis or measurement, determine application values for these six parameters:

- Nominal capacitance in μF
- Current pulse width in μs
- Current pulse period in μs
- Maximum peak voltage
- Continuous AC voltage in V_{rms}
- Maximum volt-amps

2. Choose a capacitor from the ratings table of the desired nominal capacitance with a peak voltage rating no less than your maximum peak voltage.
3. Check that your application's rms current is no more than the capacitor's Max. Amps RMS. You can calculate the current from your V_{rms} using the equations in the following section.
4. Check that your application's volt-amperes is not more than the capacitor's VA capability. The VA capability is the max VA rating times the Volt-Ampere multiplier from Figure 2 (Current Pulse Width) and that times the Volt-Ampere Multiplier from Figure 3 (Ambient Temperature). See the following section for more on using volt-ampere multipliers.

If you need a greater VA capability, repeat these steps for a higher peak voltage capacitor or consider connecting units in parallel to divide the VA required. For up to peak voltage of 600 V, you may also consider polypropylene film dielectric units, Catalog Numbers SCRN262R through SCRN266R, with higher VA capability.

Using Volt-Ampere Ratings

The capacitors maximum VA rating is the maximum product of the sinewave voltage and current that may be applied at 65°C without overheating the capacitor and reducing its expected life. For other temperatures and pulsed current, use the multipliers of Figures 2 and 3 to derate the Max VA rating.

The Max Amps RMS rating is set by the capability of the capacitor terminals. Exceeding this limit can damage the terminals and cause capacitor failure.

Calculate the capacitor's actual VA load as the product of the rms voltage across the capacitor and the rms current through the capacitor. To calculate rms current for an applied sine wave or squarewave voltage, use these equations.

For a sinewave voltage the current is:

$$I_{\text{rms}} = 2\pi f C V_{\text{rms}} \times 10^{-6}$$

and for a squarewave the current is:

$$I_{\text{rms}} = C\Delta V / 0.64(tT)^{0.5} = I_{\text{peak}}(t/T)^{0.5}$$

where f is repetition frequency in Hz, C is nominal capacitance in μF , ΔV the peak-to-peak squarewave amplitude in volts, t is the pulse width in μs and T is the pulse period in μs .

The peak current for the square wave voltage is:

$$I_{\text{peak}} = C\Delta V / 0.64t$$

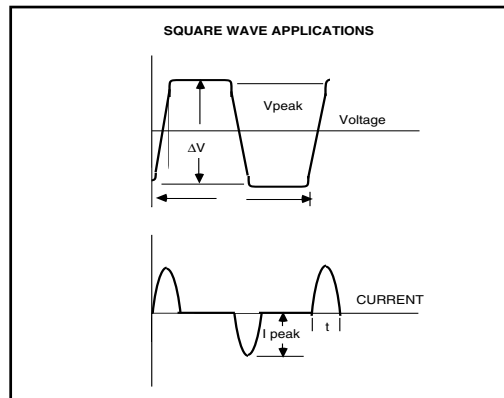

Figure 1

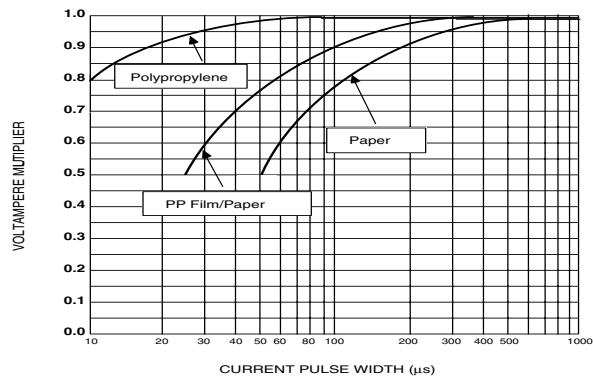

Figure 2

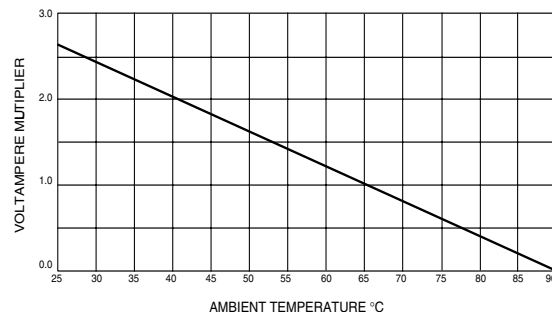

Figure 3

High-Voltage and Motor Capacitors

Type T High Voltage DC Filter Capacitors



Type T – Paper-Film/Foil

Applications

Use Type T capacitors for filter applications. Typical applications include: filtering, bypass and blocking radar amplifiers and power supplies.

Highlights

- Voltage ratings: 600 - 5000 Vdc
- Capacitance range: 0.1 μ F to 15.0 μ F
- Capacitance tolerance: \pm 10%
- Temperature range: -55°C to 85°C
- 105°C operation with derating
- Hermetically sealed for long life
- 10-32 screw terminals

High-Voltage
and
Motor Capacitors

| Cap. (μ F) | Stock Items | Catalog Number | Case Code | H (inches) |
|-----------------|-------------|----------------|-----------|------------|
| 600 Vdc | | | | |
| 0.50 | | T6P5NR | A | 2.13 |
| 1.0 | S | T6W1NR | A | 2.13 |
| 2.0 | S | T6W2NR | A | 2.13 |
| 3.0 | | T6W3NR | A | 2.38 |
| 4.0 | | T6W4NR | A | 2.88 |
| 6.0 | | T6W6NR | A | 3.00 |
| 8.0 | | T6W8NR | C | 2.88 |
| 10.0 | S | T6W10NR | C | 3.13 |
| 15.0 | | T6W15NR | D | 3.50 |
| 1000 Vdc | | | | |
| 0.10 | | T10P1NR | A | 2.13 |
| 0.25 | | T10P25NR | A | 2.13 |
| 0.50 | S | T10P5NR | A | 2.13 |
| 1.0 | S | T10W1NR | A | 2.13 |
| 2.0 | S | T10W2NR | A | 2.63 |
| 4.0 | | T10W4NR | A | 4.25 |
| 6.0 | S | T10W6NR | C | 3.50 |
| 8.0 | | T10W8NR | D | 3.50 |
| 10.0 | S | T10W10NR | D | 3.88 |
| 15.0 | | T10W15NR | D | 5.25 |
| 1500 Vdc | | | | |
| 0.50 | | T15P5NR | A | 2.13 |
| 1.0 | | T15W1NR | A | 2.13 |
| 2.0 | | T15W2NR | A | 3.13 |
| 4.0 | | T15W4NR | C | 3.13 |
| 6.0 | | T15W6NR | D | 3.88 |
| 8.0 | | T15W8NR | D | 4.25 |

| Cap. (μ F) | Stock Items | Catalog Number | Case Code | H (inches) |
|--------------------------|-------------|----------------|-----------|------------|
| 1500 Vdc (cont'd) | | | | |
| 10.0 | | T15W10NR | D | 4.75 |
| 12.0 | | T15W12NR | D | 5.25 |
| 15.0 | | T15W15NR | D | 6.25 |
| 2000 Vdc | | | | |
| 0.10 | | T20P1NR | A | 2.13 |
| 0.25 | S | T20P25NR | A | 2.13 |
| 0.50 | S | T20P5NR | A | 2.13 |
| 1.0 | S | T20W1NR | A | 2.63 |
| 2.0 | | T20W2NR | C | 2.88 |
| 4.0 | | T20W4NR | D | 3.50 |
| 5.0 | | T20W5NR | D | 4.25 |
| 8.0 | | T20W8NR | D | 5.75 |
| 10.0 | | T20W10NR | D | 6.75 |
| 15.0 | | T20W15NR | D | 9.88 |
| 2500 Vdc | | | | |
| 1.0 | | T25W1NR | C | 2.88 |
| 2.0 | | T25W2NR | C | 3.13 |
| 4.0 | | T25W4NR | D | 4.25 |
| 3000 Vdc | | | | |
| 0.10 | | T30P1NR | A | 2.13 |
| 0.50 | | T30P5NR | A | 3.13 |
| 1.0 | | T30W1NR | C | 3.13 |
| 6.0 | | T30W6NR | D | 8.00 |
| 5000 Vdc | | | | |
| 0.50 | | T50P5NR | C | 3.50 |
| 1.0 | | T50W1NR | D | 4.25 |
| 2.0 | | T50W2NR | D | 7.25 |

Type T High Voltage DC Filter Capacitors

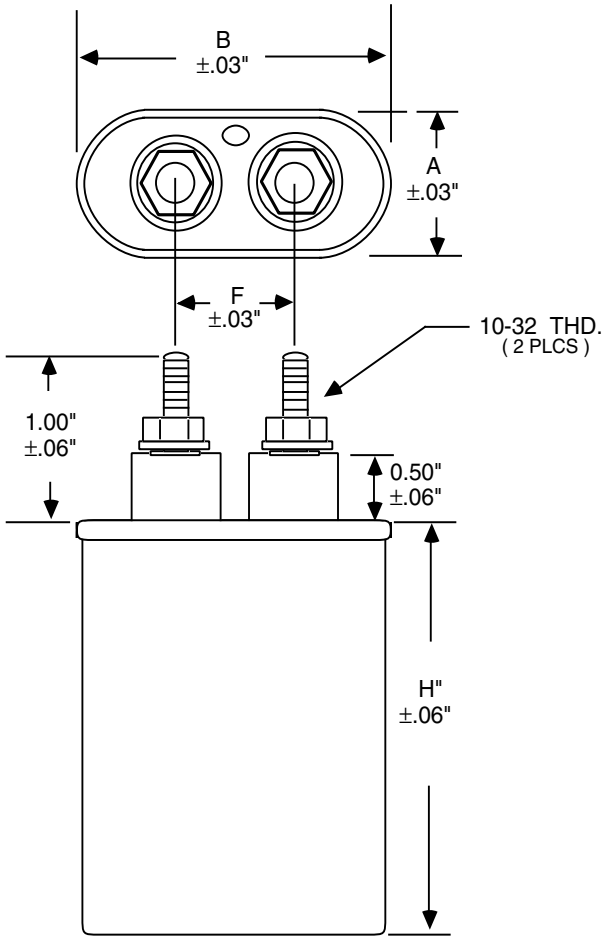

Case Code

| Case Code | Dimensions (Inches) | | | |
|-----------|---------------------|------|------|-----------|
| | A | B | F | H |
| A | 1.31 | 2.16 | 0.81 | see table |
| C | 1.91 | 2.91 | 1.38 | see table |
| D | 1.97 | 3.66 | 1.38 | see table |

Mounting Hardware

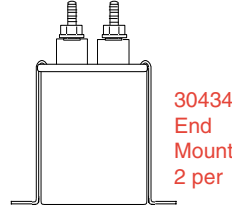

| H (Inches) | End Mount | Side Mount |
|------------|-----------|------------|
| 2.13 | 30434-33 | 31762-45 |
| 2.38 | 30434-37 | 31762-46 |
| 2.63 | 30434-41 | 31762-47 |
| 2.88 | 30434-45 | 31762-48 |
| 3.13 | 30434-49 | 31762-49 |
| 3.50 | 30434-55 | 31762-50 |
| 3.75 | 30434-59 | 31762-83 |
| 3.88 | 30434-61 | 31762-51 |
| 4.25 | 30434-67 | 31762-52 |
| 4.75 | 30434-75 | 31762-54 |
| 5.25 | 30434-83 | 31762-55 |
| 5.75 | 30434-91 | 31762-56 |
| 6.25 | 30434-99 | 31762-59 |
| 6.75 | 30434-107 | 31762-60 |
| 7.25 | 30434-115 | 31762-62 |
| 8.00 | 30434-127 | 31762-63 |

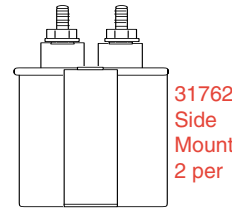

| Case Code | Bracket |
|-----------|----------|
| A | 30393-5 |
| C | 30393-9 |
| D | 30393-10 |

| Case Code | Bracket |
|-----------|---------|
| A | 32107-1 |
| C | 32107-2 |
| D | 32107-3 |

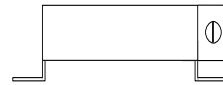
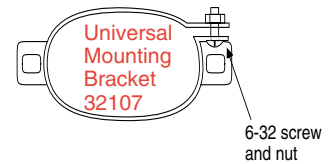

High-Voltage and Motor Capacitors



CORNELL DUBILIER

Your Source For Capacitor Solutions

1605 East Rodney French Blvd.
New Bedford, MA 02744
(508) 996-8564, Fax (508) 996-3830
<http://www.cornell-dubilier.com>
E-mail: cdenb@cornell-dubilier.com