

Type 330 $-55\text{ }^{\circ}\text{C}$ to $105\text{ }^{\circ}\text{C}$ Ultra-Long-Life, Switching Power Grade Radial

High Ripple and Ultra-Long Life

The Type 330 is the ultra-long-life version of the Type 300 capacitor. With an astonishing, 50,000-hour expected life operating continuously at full load and $65\text{ }^{\circ}\text{C}$ the 330 is the choice for power supply outputs and UPS battery stiffening. The exceptionally low ESRs enable high ripple-current capability. With series inductance of 12 to 16 nH and ripple currents to 16 amps one of these capacitors can save by replacing three or four of the 12.5 mm diameter capacitors routinely at the output of switching power supplies. Type 330 R delivers even lower ESR and higher ripple. Type 330 has three leads for rugged, reverse-proof mounting. Two leads are available as Types 331 and 331R.



Highlights

- Expected Life > 20 years @ $45\text{ }^{\circ}\text{C}$
- Ripple Current to 16 amps
- ESRs to $6\text{ m}\Omega$
- > 90% capacitance at $-40\text{ }^{\circ}\text{C}$
- Replaces multiple capacitors

[Regulatory Information](#)

Specifications

Operating Temperature:	$-55\text{ }^{\circ}\text{C}$ to $+105\text{ }^{\circ}\text{C}$
Rated Voltage:	6.3 to 250 Vdc
Capacitance:	270 μF to 33,000 μF
Capacitance Tolerance:	6.3 to 100 Vdc; $-10 + 75\%$, 160 to 250 Vdc; $-10 + 50\%$
Leakage Current:	$\leq 0.5\sqrt{\text{CV}}\text{ }\mu\text{A}$, 4 mA max, 5 min.
Cold Impedance:	$-55\text{ }^{\circ}\text{C}$ multiple of $25\text{ }^{\circ}\text{C}$ $Z \leq 4$ for 6.3 & 7.5 V, 3 for 10 to 50 V, 2 for > 50 V

Ripple Current Multipliers:

Ambient Temperature

$45\text{ }^{\circ}\text{C}$	$55\text{ }^{\circ}\text{C}$	$65\text{ }^{\circ}\text{C}$	$75\text{ }^{\circ}\text{C}$	$85\text{ }^{\circ}\text{C}$	$95\text{ }^{\circ}\text{C}$	$105\text{ }^{\circ}\text{C}$
1.66	1.52	1.37	1.20	1.00	0.75	0.36

Frequency

	50 Hz	60 Hz	120 Hz	360 Hz	1 kHz	5 kHz	10 kHz & up
.77" Diameter							
6.3 & 7.5 V	0.82	0.86	1.00	1.15	1.21	1.24	1.25
10 to 40 V	0.78	0.83	1.00	1.20	1.30	1.35	1.36
50V	0.76	0.81	1.00	1.25	1.38	1.45	1.47
63 & 75 V	0.74	0.80	1.00	1.28	1.43	1.52	1.54
100 to 250 V	0.76	0.81	1.00	1.24	1.37	1.44	1.46
.895" Diameter							
6.3 & 7.5 V	0.82	0.86	1.00	1.14	1.20	1.23	1.24
10 to 40 V	0.80	0.84	1.00	1.17	1.25	1.29	1.30
50V	0.75	0.80	1.00	1.27	1.42	1.50	1.52
63 & 75 V	0.75	0.80	1.00	1.26	1.40	1.48	1.50
100 to 250 V	0.76	0.81	1.00	1.25	1.38	1.46	1.48
1.02" Diameter							
6.3 & 7.5 V	0.84	0.88	1.00	1.12	1.17	1.19	1.20
10 to 40 V	0.81	0.86	1.00	1.15	1.22	1.25	1.26
50V	0.76	0.81	1.00	1.23	1.35	1.42	1.44
63 & 75 V	0.77	0.81	1.00	1.23	1.35	1.42	1.44
100 to 250 V	0.76	0.81	1.00	1.24	1.37	1.44	1.46

Load Life: 10,000 h at full load at $85\text{ }^{\circ}\text{C}$
 Δ Capacitance $\pm 20\%$
 ESR 200% of limit
 DCL 100% of limit

Shelf Life: 500 h at $105\text{ }^{\circ}\text{C}$, capacitance, ESR and DCL, initial requirements

Type 330 -55 °C to 105 °C Ultra-Long-Life, Switching Power Grade Radial

Outline Drawings

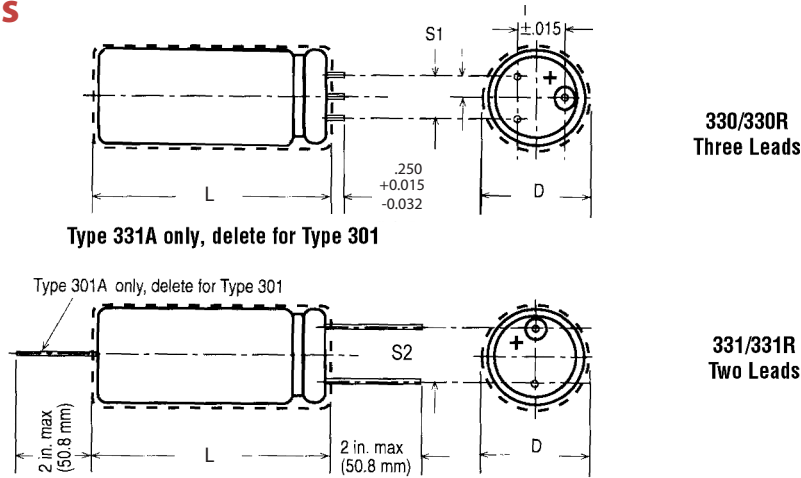

Case Dimensions

Case Code	Insulated D ± 0.015 (0.4 mm) L ± 0.062 (1.6 mm) D x L	Epoxy endseal L Max D x L	Bare Can D ± 0.015 (0.4 mm) L ± 0.030 (0.8 mm)	Lead Spacing		Lead dia.	Diameter AWG
				Type 330 S1	Type 331 S2		
				0.020 (0.5 mm)	0.020 (0.5 mm)		
Case Dimensions in Inches							
GT	0.765 x 3.650	3.712	0.750 x 3.625	0.200	0.300	0.040	18
HP	0.890 x 2.650	2.712	0.875 x 2.625	0.300	0.400	0.040	18
HS	0.890 x 3.150	3.212	0.875 x 3.125	0.300	0.400	0.040	18
HT	0.890 x 3.650	3.712	0.875 x 3.625	0.300	0.400	0.040	18
JL	1.015 x 2.150	2.212	1.000 x 2.125	0.300	0.400	0.040	18
JP	1.015 x 2.650	2.712	1.000 x 2.625	0.300	0.400	0.040	18
JS	1.015 x 3.150	3.212	1.000 x 3.125	0.300	0.400	0.040	18
JT	1.015 x 3.650	3.712	1.000 x 3.625	0.300	0.400	0.040	18
Case Dimensions in Millimeters							
GT	19.4 x 92.7	94.3	19.1 x 92.1	5.08	7.62	1.02	18
HP	22.6 x 67.3	68.9	22.2 x 66.7	7.62	10.16	1.02	18
HS	22.6 x 80.0	81.6	22.2 x 79.4	7.62	10.16	1.02	18
HT	22.6 x 92.7	94.3	22.2 x 92.1	7.62	10.16	1.02	18
JL	25.8 x 54.6	56.2	25.4 x 54.0	7.62	10.16	1.02	18
JP	25.8 x 67.3	68.9	25.4 x 66.7	7.62	10.16	1.02	18
JS	25.8 x 80.0	81.6	25.4 x 79.4	7.62	10.16	1.02	18
JT	25.8 x 92.7	94.3	25.4 x 92.1	7.62	10.16	1.02	18

Part Numbering System

330R	333	U	6R3	JS	2	E
Type	Capacitance Tolerance		Voltage	Case Code	Insulation	Epoxy
330 - 3 leads	100 = 10 μF	M = ±20%	6R3 = 6.3 V	See	0 = Bare Can	(blank) = no epoxy
330R - 3 leads	102 = 1000 μF	T = -10% +50%	063 = 63 V	Rating	1 = Polyester	E = Epoxy
331 - 2 leads		U = -10 +75%	100 = 100 V		2 = PVC	endseal
331R - 2 leads, Low ESR					8 = PVC w/ Standoffs	
331A - Laydown 3 leads					9 = Polyester w/ Standoffs	

Type 330 -55 °C to 105 °C Ultra-Long-Life, Switching Power Grade Radial

Typical Performance Curve

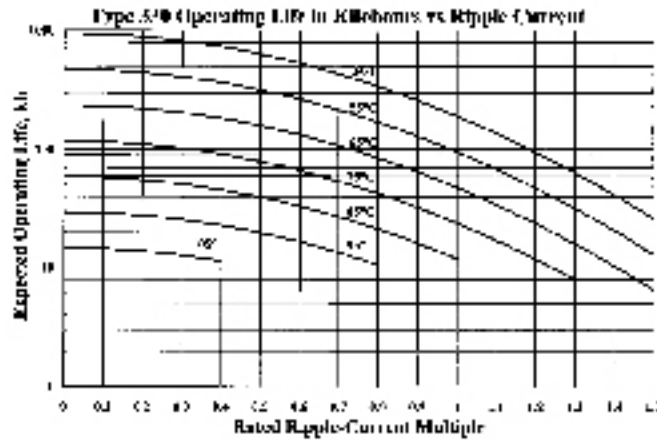

Ratings

Cap. (µF)	Catalog Part Number	ESR Max. 25 °C		Ripple Amps, Max. 85 °C		Nominal Size D X L (in)
		120 Hz (mΩ)	20 kHz (mΩ)	120 Hz (A)	20 kHz (A)	
6.3 Vdc (9 Vdc Surge)						
15000	330153U6R3GT2	26.6	15.1	7.10	8.86	0.77 X 3.65
15000	330R153U6R3GT2	23.0	13.1	7.62	9.52	0.77 X 3.65
15000	330153U6R3HP2	27.1	16.5	6.57	7.93	0.895 X 2.65
15000	330R153U6R3HP2	19.5	11.3	7.75	9.60	0.895 X 2.65
18000	330183U6R3JL2	29.6	20.1	6.08	6.95	1.02 X 2.15
18000	330R183U6R3JL2	19.1	10.9	7.57	9.45	1.02 X 2.15
22000	330223U6R3HS2	22.4	13.7	7.88	9.51	0.895 X 3.15
22000	330R223U6R3HS2	15.9	9.2	9.35	11.60	0.895 X 3.15
22000	330223U6R3JP2	23.0	15.6	7.66	8.75	1.02 X 2.65
22000	330R223U6R3JP2	14.7	8.4	9.59	12.00	1.02 X 2.65
27000	330273U6R3HT2	19.4	11.9	9.04	10.90	0.895 X 3.65
27000	330R273U6R3HT2	13.6	7.9	10.80	13.40	0.895 X 3.65
27000	330273U6R3JS2	19.2	13.0	9.11	10.40	1.02 X 3.15
27000	330R273U6R3JS2	15.1	8.6	10.30	12.80	1.02 X 3.15
33000	330333U6R3JT2	16.7	11.4	10.50	12.00	1.02 X 3.65
33000	330R333U6R3JT2	10.4	5.9	13.30	16.60	1.02 X 3.65
7.5 Vdc (10 Vdc Surge)						
12000	330123U7R5GT2	27.2	15.0	7.01	8.91	0.77 X 3.65
12000	330R123U7R5GT2	23.6	13.0	7.53	9.57	0.77 X 3.65
15000	330153U7R5HP2	27.7	16.6	6.50	7.91	0.895 X 2.65
15000	330R153U7R5HP2	20.0	11.0	7.65	9.73	0.895 X 2.65
15000	330153U7R5JL2	30.1	19.9	6.02	6.99	1.02 X 2.15
15000	330R153U7R5JL2	19.6	10.9	7.47	9.41	1.02 X 2.15
18000	330183U7R5HS2	22.9	13.8	7.79	9.48	0.895 X 3.15
18000	330R183U7R5HS2	16.3	9.0	9.23	11.74	0.895 X 3.15
22000	330223U7R5HT2	19.8	11.9	8.95	10.89	0.895 X 3.65
22000	330R223U7R5HT2	13.9	7.7	10.70	13.60	0.895 X 3.65
22000	330223U7R5JP2	23.4	15.5	7.59	8.80	1.02 X 2.65
22000	330R223U7R5JP2	15.0	8.4	9.47	11.90	1.02 X 2.65
27000	330273U7R5JS2	19.5	12.9	9.03	10.50	1.02 X 3.15
27000	330R273U7R5JS2	15.5	8.7	10.10	12.80	1.02 X 3.15
7.5 Vdc (10 Vdc Surge) (cont'd.)						
33000	330333U7R5JT2	17.0	11.2	10.40	12.10	1.02 X 3.65
33000	330R333U7R5JT2	10.6	5.9	13.10	16.60	1.02 X 3.65
10 Vdc (15 Vdc Surge)						
12000	330123U010GT2	28.3	15.0	6.88	8.91	0.77 X 3.65
12000	330R123U010GT2	24.5	13.0	7.39	9.57	0.77 X 3.65
12000	330123U010HP2	28.7	16.6	6.39	7.91	0.895 X 2.65
12000	330R123U010HP2	20.8	11.5	7.49	9.53	0.895 X 2.65
12000	330123U010JL2	31.0	19.9	5.93	6.99	1.02 X 2.15
12000	330R123U010JL2	20.3	11.4	7.33	9.23	1.02 X 2.15
15000	330153U010HS2	23.7	13.7	7.66	9.49	0.895 X 3.15
15000	330R153U010HS2	17.0	9.3	9.05	11.50	0.895 X 3.15
18000	330183U010HT2	20.5	11.9	8.81	10.90	0.895 X 3.65
18000	330R183U010HT2	14.5	8.0	10.50	13.30	0.895 X 3.65
18000	330183U010JP2	24.1	15.4	7.48	8.81	1.02 X 2.65
18000	330R183U010JP2	15.6	8.7	9.29	11.70	1.02 X 2.65
22000	330223U010JS2	20.1	12.8	8.90	10.50	1.02 X 3.15
22000	330R223U010JS2	16.1	9.0	9.94	12.50	1.02 X 3.15
27000	330273U010JT2	17.5	11.2	10.30	12.10	1.02 X 3.65
27000	330R273U010JT2	11.0	6.2	12.90	16.30	1.02 X 3.65
16 Vdc (25 Vdc Surge)						
10000	330103U016GT2	29.2	14.9	6.77	8.94	0.77 X 3.65
10000	330R103U016GT2	25.3	12.9	7.27	9.60	0.77 X 3.65
10000	330103U016HP2	29.5	17.1	6.30	7.79	0.895 X 2.65
10000	330R103U016HP2	21.6	11.9	7.36	9.36	0.895 X 2.65
10000	330103U016JL2	31.8	19.7	5.86	7.01	1.02 X 2.15
10000	330R103U016JL2	21.0	11.1	7.21	9.33	1.02 X 2.15
12000	330123U016HS2	24.4	14.1	7.55	9.35	0.895 X 3.15
12000	330R123U016HS2	17.6	9.7	8.89	11.30	0.895 X 3.15
15000	330153U016HT2	21.1	12.2	8.69	10.80	0.895 X 3.65
15000	330R153U016HT2	15.0	8.2	10.30	13.10	0.895 X 3.65
15000	330153U016JP2	24.7	15.3	7.39	8.85	1.02 X 2.65

Type 330 -55 °C to 105 °C Ultra-Long-Life, Switching Power Grade Radial

Cap. (µF)	Catalog Part Number	ESR Max. 25 °C		Ripple Amps, Max. 85 °C		Nominal Size D X L (in)
		120 Hz (mΩ)	20 kHz (mΩ)	120 Hz (A)	20 kHz (A)	
16 Vdc (25 Vdc Surge) (cont'd.)						
15000	330R153U016JP2	16.1	8.5	9.14	11.80	1.02 X 2.65
18000	330183U016JS2	20.5	12.7	8.80	10.50	1.02 X 3.15
18000	330R183U016JS2	16.6	8.8	9.79	12.70	1.02 X 3.15
22000	330223U016JT2	17.9	11.1	10.10	12.10	1.02 X 3.65
22000	330R223U016JT2	11.4	6.0	12.70	16.50	1.02 X 3.65
20 Vdc (30 Vdc Surge)						
8200	330822U020GT2	29.2	14.9	6.77	8.94	0.77 X 3.65
8200	330R822U020GT2	25.3	12.9	7.27	9.60	0.77 X 3.65
8200	330822U020HP2	29.5	16.5	6.30	7.93	0.895 X 2.65
8200	330R822U020HP2	21.6	12.1	7.36	9.28	0.895 X 2.65
8200	330822U020JL2	31.8	20.1	5.86	6.96	1.02 X 2.15
8200	330R822U020JL2	21.0	11.1	7.21	9.33	1.02 X 2.15
10000	330103U020HS2	24.4	13.7	7.55	9.52	0.895 X 3.15
10000	330R103U020HS2	17.6	9.8	8.89	11.20	0.895 X 3.15
12000	330123U020HT2	21.1	11.8	8.69	10.90	0.895 X 3.65
12000	330R123U020HT2	15.0	8.4	10.30	13.00	0.895 X 3.65
12000	330123U020JP2	24.7	15.6	7.39	8.77	1.02 X 2.65
12000	330R123U020JP2	16.1	8.5	9.14	11.80	1.02 X 2.65
15000	330153U020JS2	20.5	12.9	8.80	10.50	1.02 X 3.15
15000	330R153U020JS2	13.2	7.0	11.00	14.20	1.02 X 3.15
18000	330183U020JT2	17.9	11.2	10.10	12.00	1.02 X 3.65
18000	330R183U020JT2	11.4	6.0	12.70	16.50	1.02 X 3.65
25 Vdc (35 Vdc Surge)						
6800	330682U025GT2	31.2	15.0	6.55	8.91	0.77 X 3.65
6800	330R682U025GT2	27.0	13.0	7.04	9.58	0.77 X 3.65
6800	330682U025HP2	31.3	16.6	6.11	7.91	0.895 X 2.65
6800	330R682U025HP2	23.1	10.9	7.11	9.77	0.895 X 2.65
6800	330682U025JL2	33.5	20.1	5.71	6.94	1.02 X 2.15
6800	330R682U025JL2	22.5	11.3	6.96	9.29	1.02 X 2.15
8200	330822U025HS2	25.8	13.7	7.34	9.50	0.895 X 3.15
8200	330R822U025HS2	18.9	8.9	8.59	11.80	0.895 X 3.15
10000	330103U025HT2	22.3	11.8	8.45	10.90	0.895 X 3.65
10000	330R103U025HT2	16.0	7.5	9.96	13.70	0.895 X 3.65
10000	330103U025JP2	26.0	15.6	7.20	8.77	1.02 X 2.65
10000	330R103U025JP2	17.2	8.6	8.84	11.80	1.02 X 2.65
12000	330123U025JS2	21.6	12.9	8.59	10.50	1.02 X 3.15
12000	330R123U025JS2	14.1	7.1	10.60	14.10	1.02 X 3.15
15000	330153U025JT2	18.7	11.2	9.90	12.10	1.02 X 3.65
15000	330R153U025JT2	12.1	6.0	12.30	16.40	1.02 X 3.65
40 Vdc (60 Vdc Surge)						
4700	330472U040GT2	36.4	16.4	6.06	8.52	0.77 X 3.65
4700	330R472U040GT2	31.6	14.2	6.51	9.15	0.77 X 3.65
4700	330472U040HP2	36.2	17.4	5.68	7.73	0.895 X 2.65
4700	330R472U040HP2	27.4	12.0	6.54	9.29	0.895 X 2.65
4700	330472U040JL2	38.1	20.9	5.35	6.81	1.02 X 2.15
4700	330R472U040JL2	26.5	12.2	6.42	8.93	1.02 X 2.15
40 Vdc (60 Vdc Surge) (cont'd.)						
5600	330562U040HS2	29.7	14.3	6.84	9.31	0.895 X 3.15
5600	330R562U040HS2	22.2	9.8	7.91	11.20	0.895 X 3.15
6800	330682U040HT2	25.5	12.3	7.89	10.70	0.895 X 3.65
6800	330R682U040HT2	18.9	8.3	9.18	13.10	0.895 X 3.65
6800	330682U040JP2	29.4	16.2	6.77	8.61	1.02 X 2.65
6800	330R682U040JP2	20.2	9.3	8.17	11.40	1.02 X 2.65
8200	330822U040JS2	24.3	13.4	8.09	10.30	1.02 X 3.15
8200	330R822U040JS2	16.5	7.6	9.82	13.60	1.02 X 3.15
10000	330103U040JT2	21.0	11.5	9.35	11.90	1.02 X 3.65
10000	330R103U040JT2	14.1	6.5	11.40	15.90	1.02 X 3.65
50 Vdc (75 Vdc Surge)						
3300	330332U050GT2	44.3	16.4	5.49	8.52	0.77 X 3.65
3300	330R332U050GT2	38.4	14.2	5.90	9.15	0.77 X 3.65
3300	330332U050HP2	43.5	17.8	5.18	7.63	0.895 X 2.65
3300	330R332U050HP2	33.7	12.1	5.89	9.26	0.895 X 2.65
3900	330392U050JL2	44.9	21.6	4.93	6.71	1.02 X 2.15
3900	330R392U050JL2	32.4	12.6	5.81	8.77	1.02 X 2.15
4700	330472U050HS2	35.6	14.6	6.25	9.21	0.895 X 3.15
4700	330R472U050HS2	27.3	9.8	7.14	11.20	0.895 X 3.15
5600	330562U050HT2	30.4	12.5	7.23	10.60	0.895 X 3.65
5600	330R562U050HT2	23.1	8.3	8.30	13.00	0.895 X 3.65
5600	330562U050JP2	34.5	16.6	6.25	8.50	1.02 X 2.65
5600	330R562U050JP2	24.6	9.6	7.40	11.20	1.02 X 2.65
6800	330682U050JS2	28.4	13.6	7.48	10.20	1.02 X 3.15
6800	330R682U050JS2	20.0	7.8	8.91	13.40	1.02 X 3.15
8200	330822U050JT2	24.4	11.7	8.67	11.80	1.02 X 3.65
8200	330R822U050JT2	17.0	6.6	10.40	15.70	1.02 X 3.65
63 Vdc (90 Vdc Surge)						
2200	330222U063GT2	49.6	16.4	5.19	8.53	0.77 X 3.65
2200	330R222U063GT2	43.0	14.2	5.58	9.16	0.77 X 3.65
2700	330272U063HP2	48.4	18.4	4.92	7.52	0.895 X 2.65
2700	330R272U063HP2	37.9	12.5	5.55	9.11	0.895 X 2.65
2700	330272U063JL2	49.5	21.8	4.70	6.68	1.02 X 2.15
2700	330R272U063JL2	36.3	12.7	5.48	8.74	1.02 X 2.15
3300	330332U063HS2	39.5	15.0	5.94	9.08	0.895 X 3.15
3300	330R332U063HS2	30.7	10.1	6.73	11.10	0.895 X 3.15
3900	330392U063HT2	33.7	12.8	6.87	10.50	0.895 X 3.65
3900	330R392U063HT2	25.9	8.5	7.84	12.90	0.895 X 3.65
3900	330392U063JP2	37.9	16.7	5.96	8.47	1.02 X 2.65
3900	330R392U063JP2	27.6	9.7	6.99	11.10	1.02 X 2.65
4700	330472U063JS2	31.1	13.7	7.15	10.20	1.02 X 3.15
4700	330R472U063JS2	22.4	7.8	8.42	13.40	1.02 X 3.15
5600	330562U063JT2	26.7	11.7	8.30	11.80	1.02 X 3.65
5600	330R562U063JT2	19.0	6.6	9.83	15.70	1.02 X 3.65
75 Vdc (100 Vdc Surge)						
1800	330182U075GT2	62.7	27.0	4.62	6.64	0.77 X 3.65

Type 330 -55 °C to 105 °C Ultra-Long-Life, Switching Power Grade Radial

Cap. (µF)	Catalog Part Number	ESR Max. 25 °C		Ripple Amps, Max. 85 °C		Nominal Size D X L (in)
		120 Hz (mΩ)	20 kHz (mΩ)	120 Hz (A)	20 kHz (A)	
75 Vdc (100 Vdc Surge) (cont'd.)						
1800	330R182U075GT2	54.3	23.4	4.96	7.13	0.77 X 3.65
2200	330222U075HP2	60.6	27.9	4.39	6.11	0.895 X 2.65
2200	330R222U075HP2	48.5	20.9	4.91	7.06	0.895 X 2.65
2200	330222U075JL2	60.8	30.4	4.24	5.65	1.02 X 2.15
2200	330R222U075JL2	46.2	20.3	4.86	6.91	1.02 X 2.15
2700	330272U075HS2	49.2	22.6	5.32	7.39	0.895 X 3.15
2700	330R272U075HS2	39.1	16.8	5.96	8.57	0.895 X 3.15
2700	330272U075HT2	41.8	19.2	6.17	8.58	0.895 X 3.65
2700	330R272U075HT2	32.9	14.2	6.95	9.99	0.895 X 3.65
2700	330272U075JP2	46.4	23.2	5.39	7.18	1.02 X 2.65
2700	330R272U075JP2	35.0	15.4	6.21	8.82	1.02 X 2.65
3300	330332U075JS2	37.9	19.0	6.47	8.63	1.02 X 3.15
3300	330R332U075JS2	28.3	12.5	7.49	10.60	1.02 X 3.15
3900	330392U075JT2	32.4	16.2	7.53	10.00	1.02 X 3.65
3900	330R392U075JT2	23.9	10.5	8.76	12.40	1.02 X 3.65
100 Vdc (140 Vdc Surge)						
820	330821U100GT2	99.5	37.8	3.67	5.61	0.77 X 3.65
820	330R821U100GT2	86.2	32.8	3.94	6.02	0.77 X 3.65
1000	330102U100HP2	94.7	36.0	3.51	5.38	0.895 X 2.65
1000	330R102U100HP2	78.1	29.7	3.87	5.92	0.895 X 2.65
1000	330102U100JL2	92.7	37.1	3.43	5.12	1.02 X 2.15
1000	330R102U100JL2	73.8	28.8	3.85	5.81	1.02 X 2.15
1200	330122U100HS2	76.5	29.1	4.26	6.52	0.895 X 3.15
1200	330R122U100HS2	62.8	23.9	4.71	7.20	0.895 X 3.15
1200	330122U100HT2	64.5	24.5	4.96	7.59	0.895 X 3.65
1200	330R122U100HT2	52.6	20.0	5.50	8.41	0.895 X 3.65
1200	330122U100JP2	70.3	28.1	4.38	6.53	1.02 X 2.65
1200	330R122U100JP2	55.7	21.7	4.92	7.43	1.02 X 2.65
1500	330152U100JS2	57.0	22.8	5.28	7.87	1.02 X 3.15
1500	330R152U100JS2	44.9	17.5	5.95	8.99	1.02 X 3.15

Cap. (µF)	Catalog Part Number	ESR Max. 25 °C		Ripple Amps, Max. 85 °C		Nominal Size D X L (in)
		120 Hz (mΩ)	20 kHz (mΩ)	120 Hz (A)	20 kHz (A)	
100 Vdc (140 Vdc Surge) (cont'd.)						
2200	330222U100JT2	48.3	19.3	6.17	9.19	1.02 X 3.65
2200	330R222U100JT2	37.7	14.7	6.97	10.50	1.02 X 3.65
160 Vdc (200 Vdc Surge)						
330	330331T160GT2	306	116	2.09	3.20	0.77 X 3.65
390	330391T160HP2	268	102	2.09	3.19	0.895 X 2.65
390	330391T160JL2	278	111	1.98	2.95	1.02 X 2.15
470	330471T160HS2	226	85.7	2.48	3.80	0.895 X 3.15
470	330471T160JP2	228	91.4	2.43	3.62	1.02 X 2.65
560	330561T160HT2	189	71.8	2.90	4.44	0.895 X 3.65
560	330561T160JS2	184	73.5	2.94	4.39	1.02 X 3.15
680	330681T160JT2	154	61.6	3.45	5.15	1.02 X 3.65
200 Vdc (250 Vdc Surge)						
330	330331T200GT2	384	177	1.87	2.59	0.77 X 3.65
330	330331T200HP2	358	165	1.81	2.51	0.895 X 2.65
390	330391T200HS2	288	132	2.20	3.06	0.895 X 3.15
390	330391T200JL2	339	156	1.79	2.49	1.02 X 2.15
470	330471T200HT2	240	111	2.57	3.57	0.895 X 3.65
470	330471T200JP2	255	117	2.30	3.19	1.02 X 2.65
560	330561T200JS2	205	94.4	2.78	3.87	1.02 X 3.15
680	330681T200JT2	172	79.1	3.27	4.54	1.02 X 3.65
250 Vdc (300 Vdc Surge)						
270	330271T250GT2	455	191	1.72	2.50	0.77 X 3.65
270	330271T250HP2	423	178	1.66	2.42	0.895 X 2.65
270	330271T250JL2	400	168	1.65	2.40	1.02 X 2.15
330	330331T250HS2	340	143	2.02	2.94	0.895 X 3.15
390	330391T250HT2	284	119	2.37	3.44	0.895 X 3.65
390	330391T250JP2	301	126	2.12	3.08	1.02 X 2.65
470	330471T250JS2	242	102	2.56	3.73	1.02 X 3.15
560	330561T250JT2	202	85.0	3.01	4.38	1.02 X 3.65

Type 330 –55 °C to 105 °C Ultra-Long-Life, Switching Power Grade Radial

Notice and Disclaimer: All product drawings, descriptions, specifications, statements, information and data (collectively, the “Information”) in this datasheet or other publication are subject to change. The customer is responsible for checking, confirming and verifying the extent to which the Information contained in this datasheet or other publication is applicable to an order at the time the order is placed. All Information given herein is believed to be accurate and reliable, but it is presented without any guarantee, warranty, representation or responsibility of any kind, expressed or implied. Statements of suitability for certain applications are based on the knowledge that the Cornell Dubilier company providing such statements (“Cornell Dubilier”) has of operating conditions that such Cornell Dubilier company regards as typical for such applications, but are not intended to constitute any guarantee, warranty or representation regarding any such matter – and Cornell Dubilier specifically and expressly disclaims any guarantee, warranty or representation concerning the suitability for a specific customer application, use, storage, transportation, or operating environment. The Information is intended for use only by customers who have the requisite experience and capability to determine the correct products for their application. Any technical advice inferred from this Information or otherwise provided by Cornell Dubilier with reference to the use of any Cornell Dubilier products is given gratis (unless otherwise specified by Cornell Dubilier), and Cornell Dubilier assumes no obligation or liability for the advice given or results obtained. Although Cornell Dubilier strives to apply the most stringent quality and safety standards regarding the design and manufacturing of its products, in light of the current state of the art, isolated component failures may still occur. Accordingly, customer applications which require a high degree of reliability or safety should employ suitable designs or other safeguards (such as installation of protective circuitry or redundancies or other appropriate protective measures) in order to ensure that the failure of an electrical component does not result in a risk of personal injury or property damage. Although all product-related warnings, cautions and notes must be observed, the customer should not assume that all safety measures are indicated in such warnings, cautions and notes, or that other safety measures may not be required.