

Type ULP, 2 and 3 mm Ultra Low Profile Aluminum Electrolytic Capacitor, 85 °C

High Energy Density



At 2 and 3 mm thin, type ULP offers the highest energy density available in a low profile aluminum electrolytic. It's ideal for the lowest profile circuits where high capacitance is needed for bulk storage. Look to type ULP to replace arrays of SMT solid tantalum capacitors.

Highlights

- 2 or 3 mm profile
- High energy density .4 J/cc
- Replaces banks of solid tantalum chips
- 3000 hr life @ 85 °C without voltage derating

Specifications

Temperature Range	-40 °C to 85 °C, at 100% rated voltage
Surge Voltage	120% of the rated working Vdc
Capacitance Range	500 µF to 24,000 µF
Capacitance Tolerance	±20% at 120 Hz and 25 °C
DC Leakage Current	After a five minute application of the rated working voltage at +25 °C : $I \leq 0.001CV$
Moisture Resistance	After 500 hours storage at +60°C and 90% to 95% RH with or without load, the capacitor will meet the following limits: $\Delta C = +20\%/-20\%$ of the initial measured value. ESR \leq the initial specified value DCL \leq the initial specified value
DC Life Test	Apply rated DC working voltage at 85°C for 3000 hours, and then stabilize them to +25°C. Capacitors will meet the following limits: $\Delta C = \pm 20\%$ of the initial measured value ESR \leq the initial specified value DCL \leq the initial specified value
Shelf Life Test	Shelf life is typically 5 to 10 years. Accelerated test: After 500 hours at 85°C, capacitors will meet the initial limits after stabilization at 25°C.
Vibration <i>Mounting: Vibration capability is dependent upon mounting restraint. To achieve the high vibration levels as published on right, additional mounting restraint is required.</i>	MIL-STD-202, Meth. 204, Sine Swept, IEC 60068-2-6 Standard ULP: 10g
Low Temperature Characteristics	Impedance Ratio $Z_{-40} / Z_{+25} @ 120 \text{ Hz}$ ≤ 10 (4 Vdc - 10 Vdc) ≤ 4 (16 Vdc - 63 Vdc)
Altitude	60,000 feet max

Type ULP, 2 and 3 mm Ultra Low Profile Aluminum Electrolytic Capacitor, 85 °C

Vibration Test	<p>Level The specimens, while deenergized or operating under the load conditions specified, shall be subjected to the vibration amplitude, frequency range, and duration specified for each case size.</p> <p>Amplitude The specimens shall be subjected to a simple harmonic motion having an amplitude of either 0.06-inch double amplitude (maximum total excursion) or peak level specified above, whichever is less. The tolerance on vibration amplitude shall be ± 10 percent.</p> <p>Frequency Range The vibration frequency shall be varied logarithmically between the approximate limits of 10 to 2,000 Hz.</p> <p>Sweep Time and Duration The entire frequency range of 10 to 2,000 Hz and return to 10 Hz shall be traversed in 20 minutes. This cycle shall be performed 12 times in each of three mutually perpendicular directions (total of 36 times), so that the motion shall be applied for a total period of approximately 12 hours. Interruptions are permitted provided the requirements for rate of change and test duration are met.</p>
Typical Weight	Case DA - 17g, Case DB - 22g
Terminals	Flexible printed circuit 16 Amps for 1 second Max ($I^2t = 250 A^2s$)
Case Material	Cu/Ni/Zn (nickel - silver)

Type ULP, 2 and 3 mm Ultra Low Profile Aluminum Electrolytic Capacitor, 85 °C

Part Numbering System

ULP	243	M	4R0	DB	F2	A	0
Type	Capacitance	Tolerance	Rated Voltage	Case	Lead	Mounting Style	Insulation
ULP	243 = 24,000 μ F	\pm 20%	4R0 = 4.0 Vdc 016 = 16 Vdc	DA = 42 x 62 x 2 mm DB = 42 x 62 x 3 mm	F1 = Flex - 20pin (20 x 21 mm) F2 = Flex - 20pin (42 x 21 mm)	A = None	0 = None 1 = Polywrap

Outline Drawing

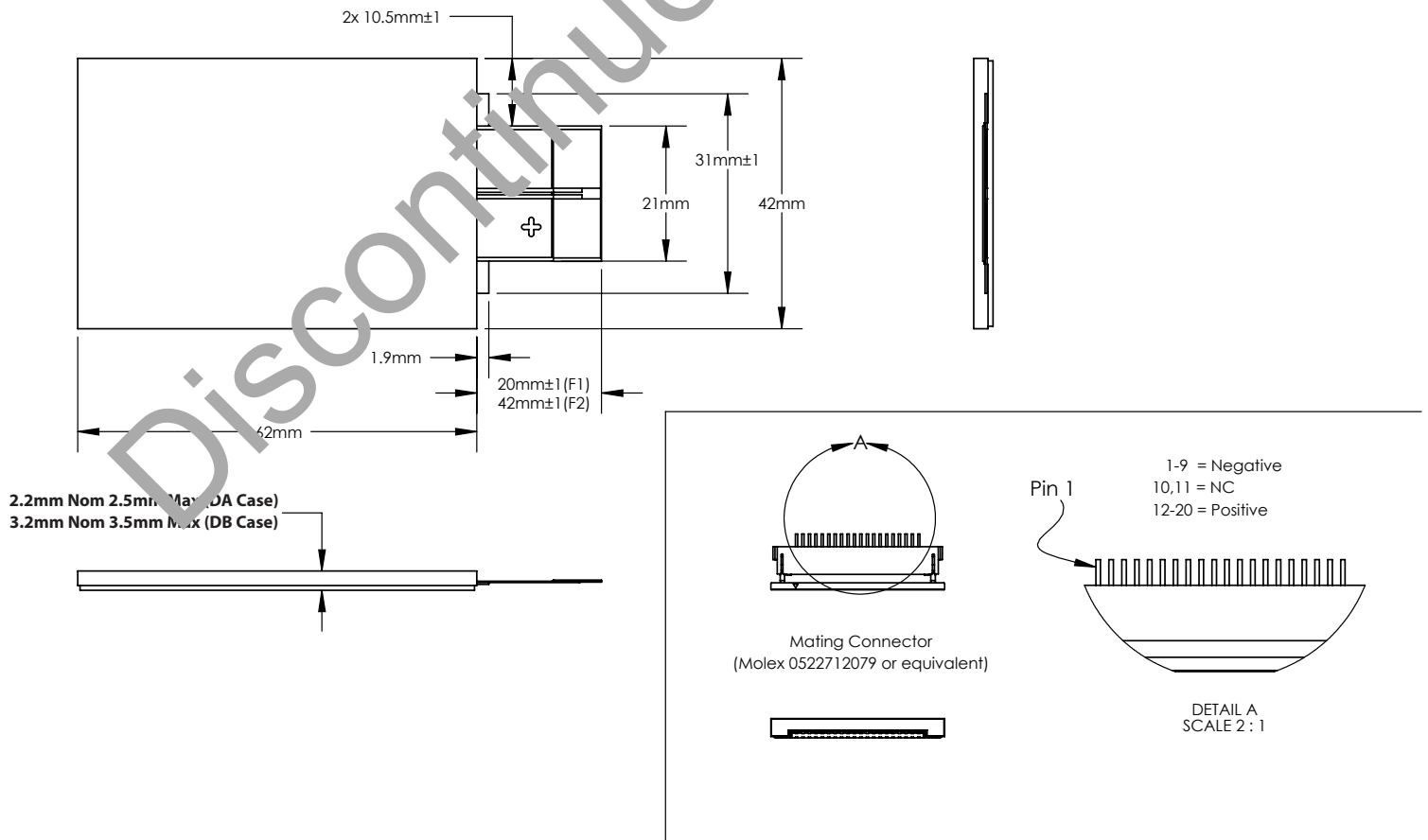

Type ULP, 2 and 3 mm Ultra Low Profile Aluminum Electrolytic Capacitor, 85 °C

Ratings

Voltage	Cap (µF)	Catalog Part Number	ESR max 25 °C mΩ 120 Hz	Surge 25 °C Vdc
2 mm				
4	7,800	ULP782M4R0DAF1A0	210	4.8
6.3	6,600	ULP662M6R3DAF1A0	210	7.56
10	5,200	ULP522M010DAF1A0	210	12
16	3,600	ULP362M016DAF1A0	210	19.2
25	2,300	ULP232M025DAF1A0	210	30
35	1,400	ULP142M035DAF1A0	210	42
50	700	ULP701M050DAF1A0	210	60
63	500	ULP501M063DAF1A0	420	75.6
3 mm				
4	24,000	ULP243M4R0DBF1A0	80	4.8
6.3	20,000	ULP203M6R3DBF1A0	80	7.56
10	15,000	ULP153M010DBF1A0	80	12
16	11,000	ULP113M016DBF1A0	80	19.2
25	6,900	ULP692M025DBF1A0	80	30
35	4,400	ULP442M035DBF1A0	80	42
50	2,200	ULP222M050DBF1A0	80	60
63	1,500	ULP152M063DBF1A0	160	75.6

Typical Performance Curves

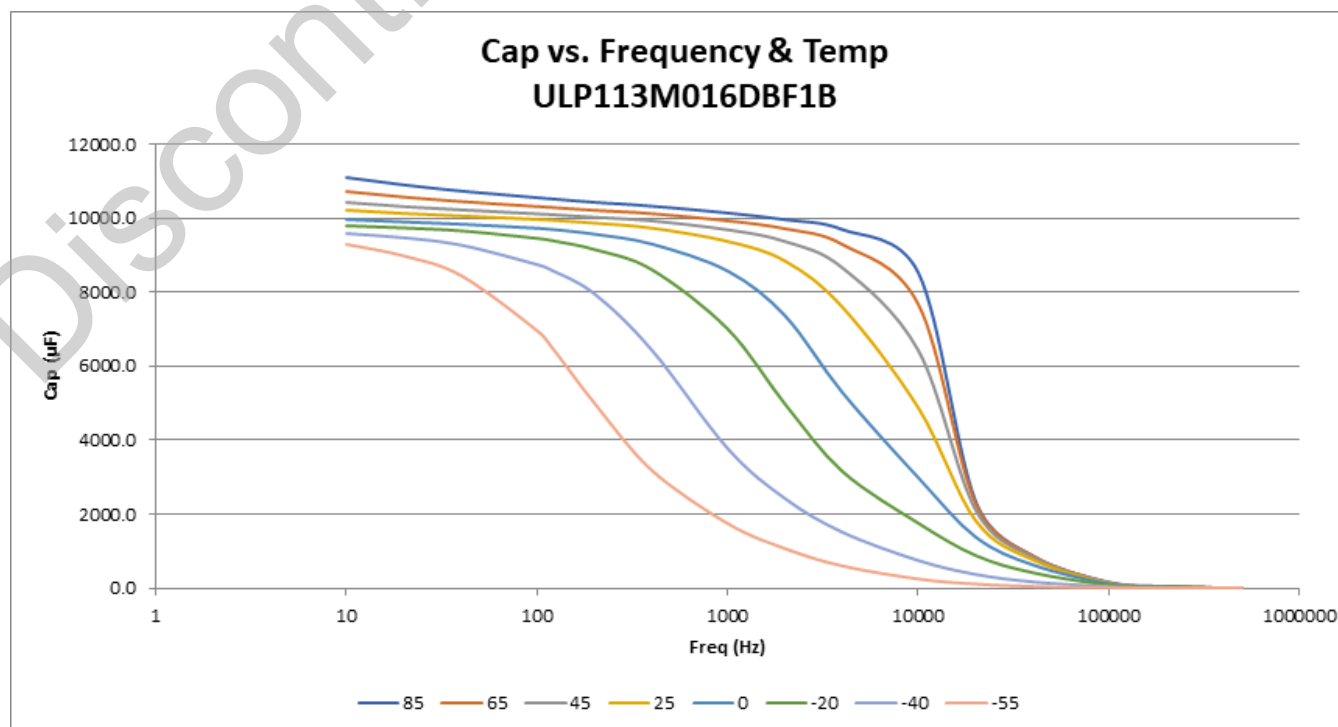

Type ULP, 2 and 3 mm Ultra Low Profile Aluminum Electrolytic Capacitor, 85 °C

Typical Performance Curves

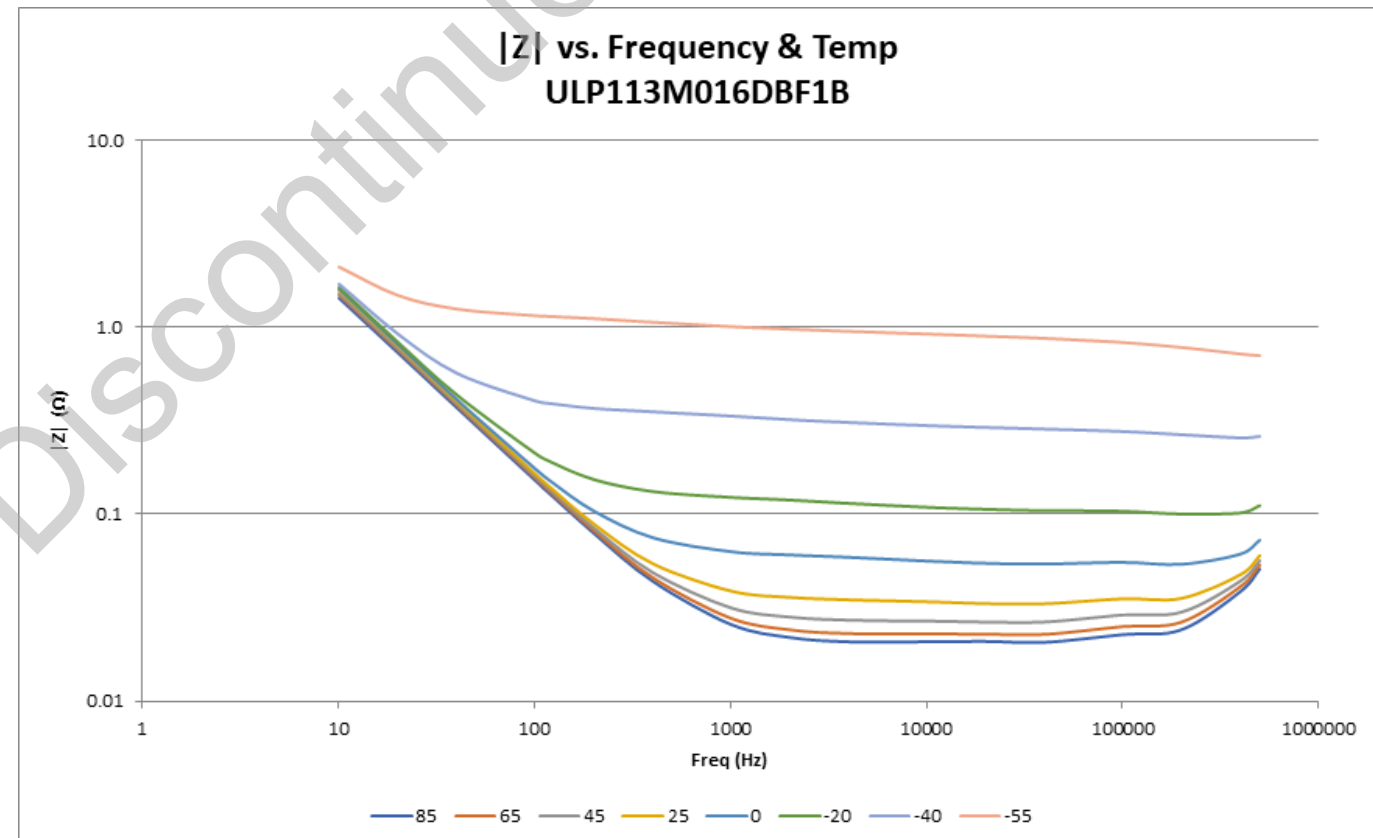
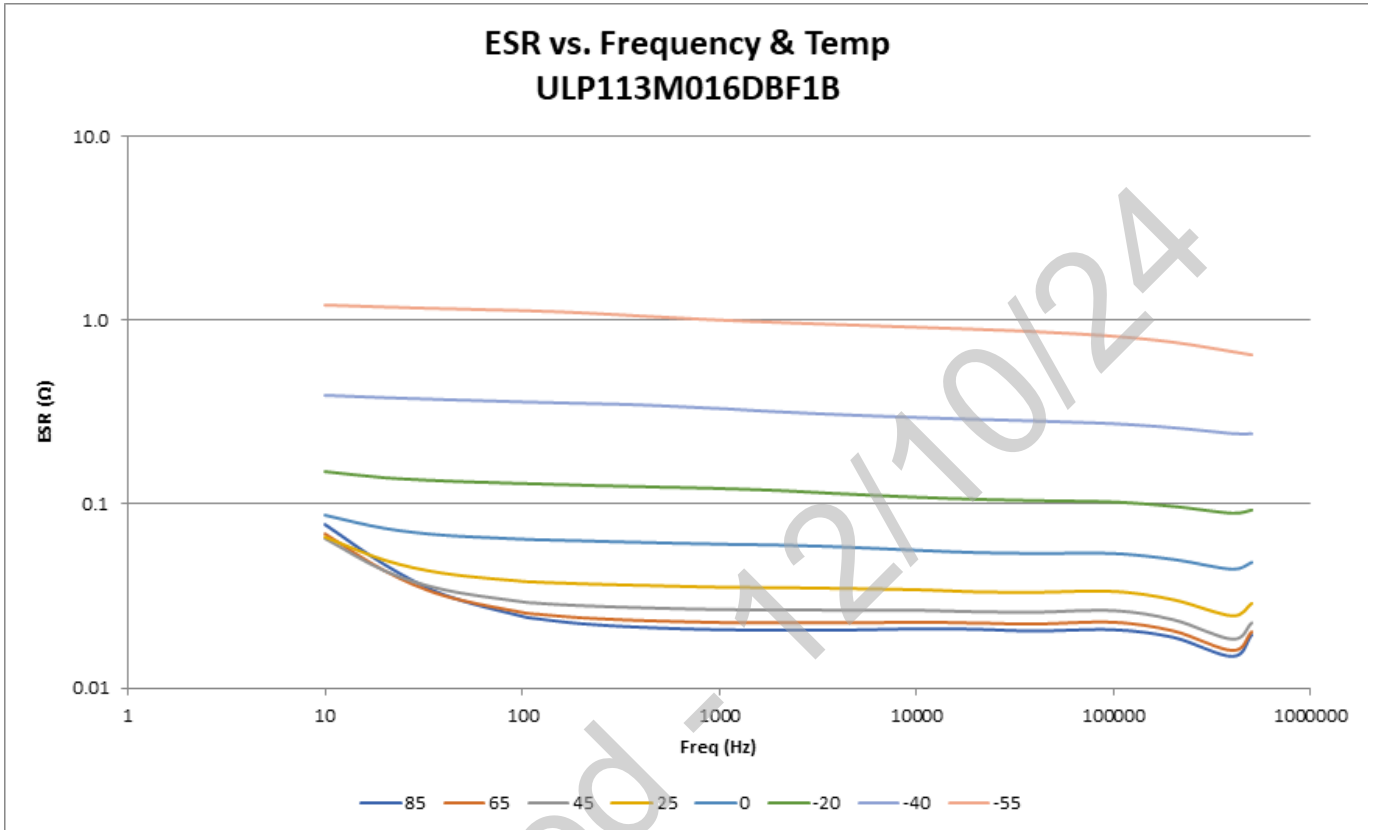

Notice and Disclaimer: All product drawings, descriptions, specifications, statements, information and data (collectively, the "Information") in this datasheet or other publication are subject to change. The customer is responsible for checking, confirming and verifying the extent to which the Information contained in this datasheet or other publication is applicable to an order at the time the order is placed. All Information given herein is believed to be accurate and reliable, but it is presented without any guarantee, warranty, representation or responsibility of any kind, expressed or implied. Statements of suitability for certain applications are based on the knowledge that the Cornell Dubilier company providing such statements ("Cornell Dubilier") has of operating conditions that such Cornell Dubilier company regards as typical for such applications, but are not intended to constitute any guarantee, warranty or representation regarding any such matter – and Cornell Dubilier specifically and expressly disclaims any guarantee, warranty or representation concerning the suitability for a specific customer application, use, storage, transportation, or operating environment. The Information is intended for use only by customers who have the requisite experience and capability to determine the correct products for their application. Any technical advice inferred from this Information or otherwise provided by Cornell Dubilier with reference to the use of any Cornell Dubilier products is given gratis (unless otherwise specified by Cornell Dubilier), and Cornell Dubilier assumes no obligation or liability for the advice given or results obtained. Although Cornell Dubilier strives to apply the most stringent quality and safety standards regarding the design and manufacturing of its products, in light of the current state of the art, isolated component failures may still occur. Accordingly, customer applications which require a high degree of reliability or safety should employ suitable designs or other safeguards (such as installation of protective circuitry or redundancies or other appropriate protective measures) in order to ensure that the failure of an electrical component does not result in a risk of personal injury or property damage. Although all product-related warnings, cautions and notes must be observed, the customer should not assume that all safety measures are indicated in such warnings, cautions and notes, or that other safety measures may not be required.

Discontinued