

Metallized Polypropylene Film Energy Storage Capacitors For Low Pulse Duty

Ralph M. Kerrigan
CDE Capacitor Division
204 Carolina Drive
Snow Hill, NC 28580
Tel: (252) 747-5943

Email: rkerriga@cde.com

Abstract

Most capacitors for external defibrillator applications use metallized polypropylene film with an electrode manufactured to permit high energy density without the risk of dielectric failure. This paper describes an evaluation of capacitors using this film and electrode type that can be used for medical defibrillators or other applications requiring a high voltage pulse capacitor. Methods for increasing energy density and reducing mass such as flat cross section capacitor elements and resin sealing versus oil filled metal cans are discussed.

A desirable feature in low pulse duty capacitors is that they can be stored for ten years or more without use, and reliably operate when required. The metallized film employed has an electrode that is usually a very thin aluminum layer that becomes oxidized when not adequately protected. Therefore humidity aging is performed with data provided and this testing is performed at various temperature levels. The required performance is for a soft aging or a reduction in capacitance safely beyond proposed application cycles, and some devices are manufactured and demonstrated to meet the proposed conditions in the paper. A discussion is presented on what condition extremes cause failures for the demonstrated devices and some failures are instigated to provide an understanding of the limitations of this metallized film capacitor type.

Introduction

Metallized polypropylene energy storage capacitors for low pulse duty are those that are required to use their stored energy intermittently or only just one time. This means that the required capacitor life expectancy is relatively short compared with most capacitor applications. Applications for low pulse duty capacitors include cardiac defibrillators, lasers, military systems and high-energy research. These applications make use of the described capacitor technology because it affords higher stored energy per unit volume and mass than longer life designs.

The term low pulse duty means there is an adequate rest period between pulse waveforms and the number of pulses is a relatively small finite value. The required rest period depends on factors such as wave-shape, peak current and operating temperature. The term finite value means a known number of pulses can be achieved consistently at a defined reliability level.

The term metallized polypropylene energy storage capacitors covers three distinct technologies. These are that a film dielectric is used in the capacitor construction, the electrodes that carry the current in the capacitor during charge and discharge are vacuum deposited on the surface of the film and the metallized dielectric has been fabricated into a capacitor. It is the refinement of the three technologies which allows increased energy density per unit mass and volume in the 21st century over those previously available.

Metallized polypropylene capacitor construction has been documented in many sources. Only a brief description is provided here to highlight construction improvements. Figure 1 shows a wound metallized film capacitor. The

most common construction shown has two metallized films wound together in a cylindrical fashion. The wound capacitor element either remains round or is flattened. The flattened cross section element is preferred for increased energy densities due to the almost rectangular cross-section.

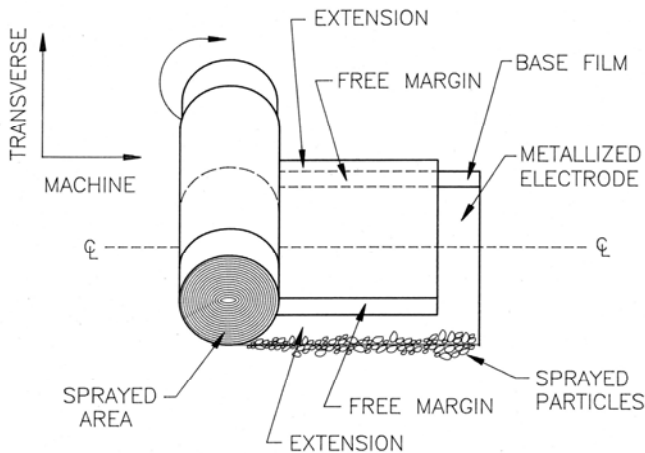

Figure 1. Typical wound film capacitor construction

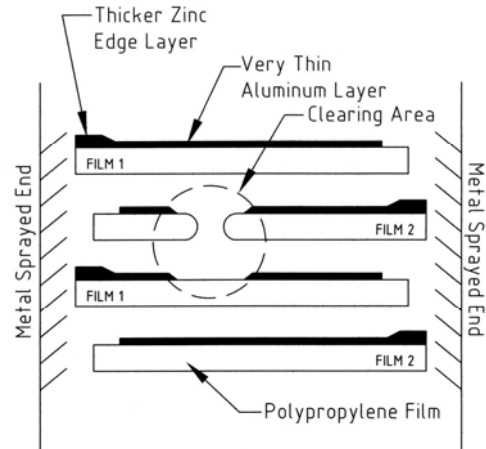

Figure 2. Metallized film layers depicting a self-healing event.

Each film in the capacitor element has a thin metallization applied to the surface, usually aluminum or zinc with a thickness typically less than 100 nm thick. [1] The metallization allows phenomena called self-healing where a localized breakdown in the film during operation due to pinholes, flaws or impurities is removed from the capacitor. A schematic picture of the self-healing process is shown in Figure 2 that also depicts the reinforced edge that will be discussed. What happens when the self-healing occurs can lead to additional flaws in the dielectric with further breakdown or to normal continued operation that will also be further discussed.

Metallized Polypropylene Low Pulse Duty Electrodes

It has been found that a very thin layer of aluminum can be applied to the surface of the polypropylene dielectric and achieve an operating voltage for these increased energy density capacitors approximately 75% of the rated breakdown voltage of the dielectric. It can be demonstrated that the energy density is proportional to the square of the achieved operating voltage by the following expression:

$$E \text{ (Joules)} = \frac{1}{2}CV^2$$

The ability to increase the breakdown voltage is inversely proportional to the metallization thickness deposited on the film. Figure 3 shows this inverse proportionality for aluminum metallized polypropylene. Although the aluminum metallization can be applied extremely thin to the main dielectric body, enough metal must be applied to the reinforced electrode edge to prevent end edge contact failures [2]. A recent improvement is that the metal on the edge has primarily been converted to zinc and this has allowed a much greater ratio of edge to body metal thickness without an unacceptable distortion of the polypropylene dielectric. Capacitors can now be designed with very thin metallization in the body to allow self-healing and enough metal on the edge to handle high current pulses.

The watts generated during charge and discharge of the energy storage capacitor has a direct proportionality to the thickness of the applied metal. For the reinforced edge construction, the thin body is more of the determining factor in power dissipation [3]. Therefore a light body is chosen to allow the high dielectric strength yet beyond a determined value significant heating may occur during charge and discharge cycles. Therefore adequate protection of the wound capacitor element must be contemplated from humidity to prevent electrode oxidation.

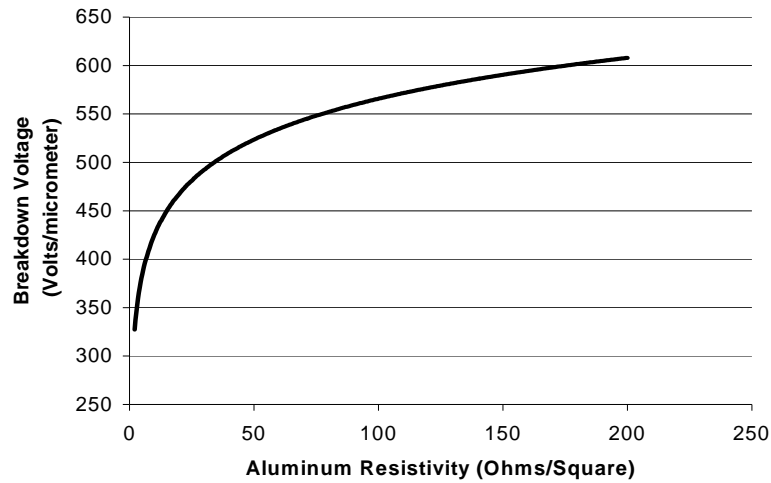

Figure 3: Polypropylene breakdown voltage versus aluminum metallization thickness. The term ohms/square is an industry standard measurement.

Experimental

Two metallized polypropylene films of 5 and 10 micrometer thickness were selected. These films had a high resistivity aluminum body of approximately 100 ohms/square and edges reinforced with zinc. Capacitors were made using flat cross-section windings on an automated winding machine with precision tension controls. The flat cross-section winding technology was chosen since it has increased volumetric efficiency. The flat cross-section was accomplished by winding around a mandrel that automatically collapses and extracts from the wound capacitor element. The machine then crushed the wound element to a fixed thickness. The flattened metallized polypropylene elements were then thermally stabilized under pressure and a metal spray was applied to each end. The processed metallized polypropylene capacitor elements were then packaged in either plastic or metal cases filled with either epoxy or polyurethane.

Table 1 shows the samples that were fabricated and a summary of the tests which were performed on each group. Two different humidity tests were performed designated groups A and B. The first was 10 days at 95% humidity and 65°C with no voltage applied and the second was 21 days at 95% humidity and 50°C with one pulse every five minutes. The 50°C temperature was chosen to accelerate a widely used 21 day, 40°C humidity test such as Mil-STD-202F Method 103B. The first test is believed to be more severe based upon previous testing at the 65°C temperature. The parts made for the 65°C test were packaged in metal cans due to a specific manufacturing need during the test period. The purpose was not to develop specific acceleration factors for humidity during these two tests but rather to show a reliable resin sealing method was possible for a capacitor with this dielectric type.

Test groups C and D are examples of accelerated pulse aging with the same design at two different temperatures. These temperatures were 23°C and 55°C. The procedure was to charge each capacitor within 5 seconds, hold 5 seconds and then discharge the capacitors into a 5 ohm load at a stress of 460 volts/micrometer. This procedure allowed no rest between pulses. The capacitors were monitored during the 1000 cycle test. It was found that the capacitance change was not significant on the room temperature group and had an increase of less than 1% on 5 of the six capacitors tested at 55°C. One of the six capacitors tested at 55°C had a dielectric failure at 464 cycles.

Group	Units	Dielectric Thickness (μM)	Capacitance (μF)	Test Type	Test Environment	Test Duration	Peak Voltage	Peak Current (Amps)
A	12	5	100	Humidity	95% RH, 65°C	10 Days	None	None
B	6	5	100	Humidity/Pulse 1per 5 minutes	95% RH, 50°C	21 Days	2200	100
C	6	5	100	Pulse voltage, 1 per 10s	23°C	1000 Cycles	2300	500
D	6	5	100	Pulse voltage, 1 per 10s	55°C	1000 Cycles	2300	500
E	6	10	40	DC voltage	50°C	10 Hours	3850	None
F	6	10	40	DC voltage	50°C	10 Hours	4000	None
G	6	10 (x2)	300	Pulse voltage, 1 per 10 min	23°C	100 Cycles	10,000	25,000

Table 1. Capacitor test groups

Test groups E and F are examples of steady state DC aging at two different voltages at the same accelerated temperature of 50°C. Although a low pulse duty capacitor is not normally designed for this type of duty there is often a significant hold time in some applications between when full charge is achieved and the capacitor is discharged. In this testing it was determined that the capacitance change was very large after 10 hours at 400 volts/micrometer of metallized polypropylene thickness. The test was therefore repeated by reducing the voltage to 385 volts per micrometer of metallized polypropylene thickness.

Test group G was an example of a larger energy storage capacitor at a higher stress in order to push the envelope of what had been achieved. This capacitor was using capacitor elements fabricated with a metallized polypropylene dielectric thickness of ten micrometers. In this capacitor design two elements were wired in series and multiple elements in parallel to produce a capacitor of 300 μF with a voltage rating of 10,000 volts peak. The voltage stress on this design was 500 volts per micrometer and the stored capacitor energy was 15 kilojoules. This capacitor was charged to its rated voltage of 10,000 volts dc and discharged after 10 seconds thru a 0.4 ohm load. After 100 cycles, no failures were produced in the six samples with less than a 1% capacitance drop.

Results

No failures occurred in either of the two humidity tests. The capacitors in the 65°C humidity test exhibited almost no capacitance change over the 10-day test period. The capacitors that were tested under 50°C humidity with periodic pulsing of one every 5 minutes exhibited a capacitance loss of less than 0.75%. The 21-day test period is equivalent to 508 hours and figure 4 shows the capacitance change measured every 100 hours during this testing. The capacitors were opened and analyzed after this testing was completed to determine the source of this small capacitance loss. There was no metal erosion typical of moisture penetration observed and self-healing or clearing sites were found mostly toward the outside of the capacitor elements and concentrated on the lower tension flat surfaces. The observation of a higher concentration of clearings on the wound element outside and the lower tension surfaces is an expected one and has been reported in other sources [1,4].

The dielectric stress level for the 1000 cycle pulse testing at 23°C and 55°C produced the single dielectric failure at the 55°C test condition. This capacitor was opened to determine the cause of the failure. The failure was found towards the inside of the capacitor element and in the transition between the radius and the flat area of the element. The failure of one capacitor element at the 55°C condition is believed to be at least partially caused by self- heating

from the repetitive pulse condition at the accelerated temperature. Similar testing has been performed at 45°C with no failures produced.

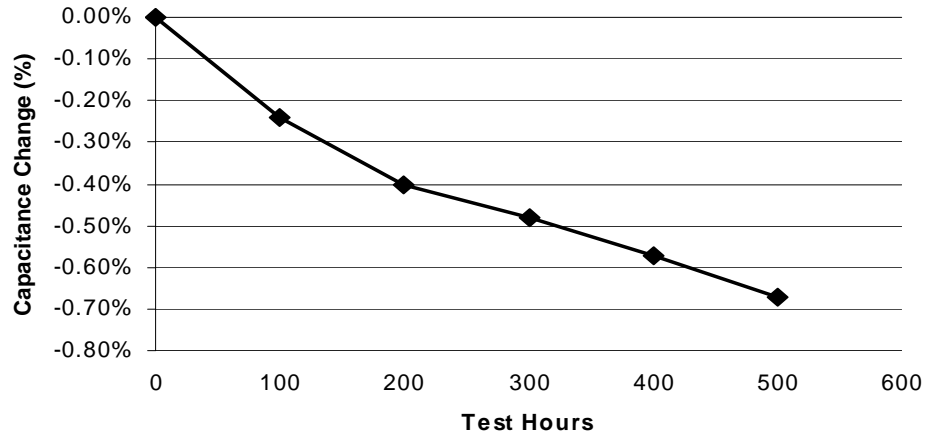

Figure 4. Capacitance change during 10 day humidity test with periodic pulsing

The results of the voltage hold testing for 10 hours at 50°C are depicted in Figure 5. It can be observed that after 2.5 hours capacitance loss was a few percent at 400 volts/μm and over 70% at 10 hours. At the 385 volts/μm condition the capacitance loss was only a few percent after 10 hours. This type of testing shows that a total amount of hold time versus temperature and voltage can be determined experimentally.

The final test group G shows a larger capacitor can be manufactured using this low pulse duty metallized polypropylene capacitor technology. Figure 6 depicts finished packaged capacitor energy in Joules per cubic centimeter. The capacitors in cases described in this paper are in the range of 1.2 to 1.5 J/cc. The group G capacitor was approximately 1.5 J/cc and was approximately 1.5 Kilo-joule per Kilo-gram. Achieving this type of design in a plastic case plastic without oil impregnation increases the size and weight density by approximately 10%.

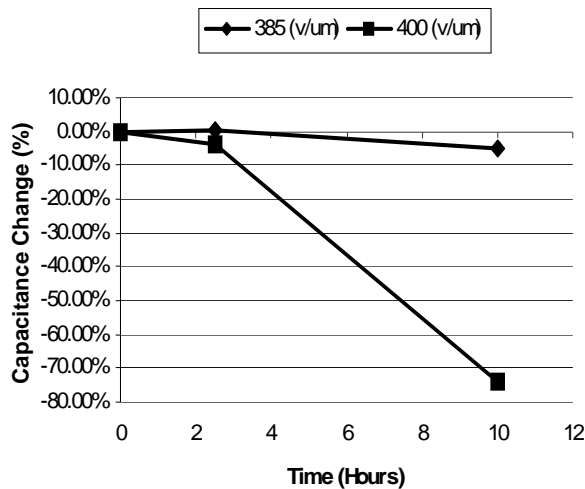

Figure 5. Capacitance change for continuous dc voltage at 50°C

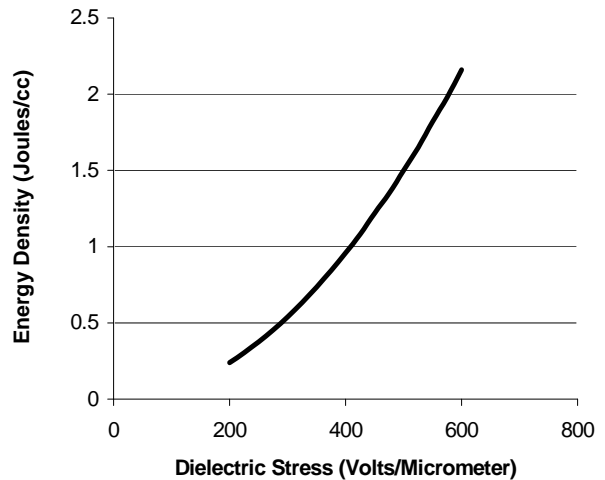

Figure 6. Energy density versus dielectric stress

Conclusion

This study has shown that metallized polypropylene energy storage capacitors can achieve a new level of energy density for low pulse duty. This energy density improvement is allowed by evolutions in wound metallized polypropylene capacitor technology. These improvements include the ability to make a reliable thin aluminum electrode body with adequate pulse handling capability as well as have a flat cross section capacitor element packaged with an epoxy or polyurethane encapsulation. Specific life requirements can be reliably achieved for each application depending on the required number of pulse cycles and type of duty. The capacitors can be used immediately after manufacturing or many years in the future.

References

- [1] C.W. Reed, S.W. Cichanowski, "The Fundamentals of Aging in HV Polymer-film Capacitors", IEEE Transactions on Dielectrics and Electrical Insulation, Vol. 1 No. 5, October 1994.
- [2] A. Borghetti, C.A. Nucci, G. Pasini, S. Pirani, M. Rinaldi, "Tests on Self-Healing Metallized Polypropylene Capacitors For Power Applications", IEEE Transactions on Power Delivery, Vol. 10, No.1, January 1995.
- [3] X. Qi, S. Boggs, "Analysis of the Effects of End Connection Quality on the Dielectric Loss of Metallized Film Capacitors", IEEE Transactions on Dielectrics and Electrical Insulation, Vol. 11, No. 6, December 2004.
- [4] M.H. EL-Husseini, P. Venet, G. Rojat, M. Fatallah, "Effect of the Geometry on the Aging of Metallized Polypropylene Film Capacitors," IEEE 32nd Annual Power Electronics Specialists Conf. (PESC 2001) Vol 4.